



ROOF MOUNTED FANS

CRHB / CRHT Series

Horizontal discharge

NEW



Range of centrifugal roof mounted fans in horizontal discharge format:

- Very low profile design.
 - Bases manufactured from galvanised sheet steel.
 - Centrifugal backward curved impeller.
 - External rotor motor.
 - Cowl manufactured from spun aluminium.
- Available, depending upon the model, with single or three phase motors in 2, 4, 6, or 8 poles.

Motors

All motors are IP54, Class F insulation with safety thermal overload protection.

Electrical supply:

Single phase 230V-50Hz (CRHB).

Three phase 400V-50Hz (CRHT).

Speed controllable by Voltage.

Additional information

ON-OFF electrical isolation switch fitted.

On request

Models from 355 to 630 can be fitted with 2-speed motors.



APPLICATIONS



Warehouses



Workshops



Commercial premises



Offices



Car Parks



Industrial and commercial kitchens

Low profile



External rotor motor to limit the height of the fan

Bird proof guard



Steel finger proof guard

Isolation switch



ON-OFF electrical isolation switch fitted on the fan as standard

CRHB/CRHT

Roof mounted fans

ROOF MOUNTED FANS

CRVB / CRVT Series

Vertical discharge

NEW



Range of centrifugal roof mounted fans in vertical discharge format:

- Very low profile design.
- Bases manufactured from galvanised sheet steel.
- Centrifugal backward curved impeller.
- External rotor motor.
- Cowl manufactured from spun aluminium.

Available, depending upon the model, with single or three phase motors in 2, 4, 6, or 8 poles.

Motors

All motors are IP54, Class F insulation with safety thermal overload protection.

Electrical supply:

Single phase 230V-50Hz (CRHB).

Three phase 400V-50Hz (CRHT).

Speed controllable by Voltage.

Additional information

ON-OFF electrical isolation switch fitted.

On request

Models from 355 to 630 can be fitted with 2-speed motors.

CRVB/CRVT

Roof mounted fans

APPLICATIONS



Backward curved centrifugal impellers



To prevent accumulation of dirt

Bird proof guard

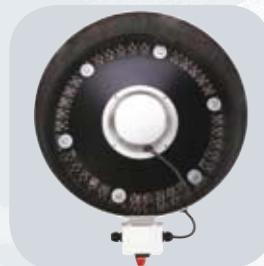

Steel finger proof guard

Isolation switch



ON-OFF electrical isolation switch fitted on the fan as standard

■ Technical characteristics CRHB/CRHT

Before making any electrical connection ensure that the voltage and frequency of the mains electrical supply matches that of the fan data plate label.

Model	Supply / Voltage (V-Hz)	Speed (r.p.m.)	Maximum power absorbed (W)	Maximum current absorbed (A) at 50Hz		Maximum air volume (m ³ /h)	Sound pressure level at 1'5 m (dB(A))		Maximum temperature (°C)	Weight (Kg)	Speed controller *
				at 230 V	at 400 V		Inlet	Outlet			
SINGLE PHASE											
CRHB/2-225	230-50/60	2450	140	0,63		1100	58	64	50	7	REB-1N
CRHB/2-250	230-50/60	2450	140	0,63		1150	58	64	70	7,5	REB-1N
CRHB/4-225	230-50/60	1450	50	0,25		670	48	54	60	7	REB-1N
CRHB/4-250	230-50/60	1450	50	0,25		795	51	54	70	7,5	REB-1N
CRHB/4-280	230-50/60	1400	85	0,40		1300	47	53	50	8	REB-1N
CRHB/4-315	230-50/60	1400	140	0,60		1844	58	61	70	17	REB-1N
CRHB/4-355	230-50	1370	230	0,85		3000	63	64	70	21	REB-1N
CRHB/4-400	230-50/60	1400	410	2		4205	64	67	60	22	REB-2,5N
CRHB/4-450	230-50/60	1350	540	2,40		5970	68	73	70	42	REB-5
CRHB/4-500	230-50	1400	1200	5,20		8300	71	76	70	44	REB-10
CRHB/6-315	230-50	965	70	0,40		1200	48	52	70	17	REB-1N
CRHB/6-355	230-50	950	80	0,4		1960	58	58	70	21	REB-1N
CRHB/6-400	230-50/60	935	150	0,7		2637	58	58	60	22	REB-1N
CRHB/6-450	230-50/60	900	260	1,20		4160	59	61	70	26	REB-2,5N
CRHB/6-500	230-50	890	340	1,50		4958	58	63	70	27	REB-2,5N
CRHB/6-560	230-50	895	640	2,75		7170	59	64	70	30	REB-5
CRHB/6-630	230-50	910	1000	4,90		9800	59	64	50	50	REB-5
CRHB/8-500	230-50	690	270	1,30		4000	51	56	60	27	REB-2,5N
CRHB/8-560	230-50	650	360	1,6		5250	51	55	60	30	REB-2,5N
CRHB/8-630	230-50	670	460	2,1		7190	53	58	70	50	REB-2,5N
THREE-PHASE											
CRHT/4-315	400-50/60	1440	140		0,6	1830	58	62	70	17	RMT-1,5
CRHT/4-355	400-50/60	1410	190		0,6	3142	64	68	60	21	RMT-1,5
CRHT/4-400	400-50/60	1340	290		0,7	4200	63	66	70	22	RMT-1,5
CRHT/4-450	400-50/60	1215	650		1,20	5770	66	71	70	42	RMT-1,5
CRHT/4-500	400-50/60	1400	800		1,6	8160	69	74	60	44	RMT-3,5
CRHT/4-560	400-50	1290	1800		3,15	10800	70	76	40	47	RMT-3,5
CRHT/6-315	400-50/60	990	85		0,45	1250	48	52	70	17	RMT-1,5
CRHT/6-355	400-50/60	975	120		0,40	2068	58	58	70	21	RMT-1,5
CRHT/6-400	400-50/60	950	125		0,4	2776	59	58	60	22	RMT-1,5
CRHT/6-450	400-50/60	920	175		0,44	4050	59	62	70	26	RMT-1,5
CRHT/6-500	400-50/60	915	250		0,62	5294	59	64	70	27	RMT-1,5
CRHT/6-560	400-50/60	900	400		1	7345	59	64	50	30	RMT-1,5
CRHT/6-630	400-50/60	915	800		1,9	10330	60	65	50	50	RMT-3,5
CRHT/6-710	400-50	912	2400		4,8	16400	68	72	70	55	RMT-8
CRHT/8-500	400-50/60	690	180		0,65	4110	49	53	60	27	RMT-1,5
CRHT/8-560	400-50/60	650	240		0,7	5270	51	54	60	30	RMT-1,5
CRHT/8-630	400-50/60	635	300		0,7	7110	53	57	70	50	RMT-1,5
CRHT/8-710	400-50/60	617	866		2,08	11285	61	66	60	75	RMT-3,5

* Three phase speed controllers (RMT) are suitable for 400V.



■ Technical characteristics CRVB/CRVT

Before making any electrical connection ensure that the voltage and frequency of the mains electrical supply matches that of the fan data plate label.

Model	Supply / Voltage (V-Hz)	Speed (r.p.m.)	Maximum power absorbed (W)	Maximum current absorbed (A) at 50Hz		Maximum air volume (m ³ /h)	Sound pressure level at 1'5 m (dB(A))		Maximum temperature (°C)	Weight (Kg)	Speed controller *
				at 230 V	at 400 V		Inlet	Outlet			
SINGLE PHASE											
CRVB/2-225	230-50/60	2450	140	0,63		1100	58	64	50	7,5	REB-1N
CRVB/2-250	230-50/60	2450	140	0,63		1150	58	64	70	8	REB-1N
CRVB/4-225	230-50/60	1450	50	0,25		670	48	54	60	7,5	REB-1N
CRVB/4-250	230-50/60	1450	50	0,25		795	51	54	70	8	REB-1N
CRVB/4-280	230-50/60	1400	85	0,40		1300	47	53	50	12	REB-1N
CRVB/4-315	230-50/60	1400	140	0,60		1844	58	61	70	19	REB-1N
CRVB/4-355	230-50	1370	230	0,85		3000	63	64	70	24	REB-1N
CRVB/4-400	230-50/60	1400	410	2		4205	64	67	60	25	REB-2,5N
CRVB/4-450	230-50/60	1350	540	2,40		5970	68	73	70	43	REB-5
CRVB/4-500	230-50	1400	1200	5,20		8300	71	76	70	45	REB-10
CRVB/6-315	230-50	965	70	0,40		1200	48	52	70	19	REB-1N
CRVB/6-355	230-50	950	80	0,4		1960	58	58	70	24	REB-1N
CRVB/6-400	230-50/60	935	150	0,7		2637	58	58	60	25	REB-1N
CRVB/6-450	230-50/60	900	260	1,20		4160	59	61	70	27	REB-2,5N
CRVB/6-500	230-50	890	340	1,50		4958	58	63	70	28	REB-2,5N
CRVB/6-560	230-50	895	640	2,75		7170	59	64	70	32	REB-5
CRVB/6-630	230-50	910	1000	4,90		9800	59	64	50	53	REB-5
CRVB/8-500	230-50	690	270	1,30		4000	51	56	60	28	REB-2,5N
CRVB/8-560	230-50	650	360	1,6		5250	51	55	60	32	REB-2,5N
CRVB/8-630	230-50	670	460	2,1		7190	53	58	70	53	REB-2,5N
THREE-PHASE											
CRVT/4-315	400-50/60	1440	140		0,6	1830	58	62	70	19	RMT-1,5
CRVT/4-355	400-50/60	1410	190		0,6	3142	64	68	60	24	RMT-1,5
CRVT/4-400	400-50/60	1340	290		0,7	4200	63	66	70	25	RMT-1,5
CRVT/4-450	400-50/60	1215	650		1,20	5770	66	71	70	43	RMT-1,5
CRVT/4-500	400-50/60	1400	800		1,6	8160	69	74	60	45	RMT-3,5
CRVT/4-560	400-50	1290	1800		3,15	10800	70	76	40	49	RMT-3,5
CRVT/6-315	400-50/60	990	85		0,45	1250	48	52	70	19	RMT-1,5
CRVT/6-355	400-50/60	975	120		0,40	2068	58	58	70	24	RMT-1,5
CRVT/6-400	400-50/60	950	125		0,4	2776	59	58	60	25	RMT-1,5
CRVT/6-450	400-50/60	920	175		0,44	4050	59	62	70	27	RMT-1,5
CRVT/6-500	400-50/60	915	250		0,62	5294	59	64	70	28	RMT-1,5
CRVT/6-560	400-50/60	900	400		1	7345	59	64	50	32	RMT-1,5
CRVT/6-630	400-50/60	915	800		1,9	10330	60	65	50	53	RMT-3,5
CRVT/6-710	400-50	912	2400		4,8	16400	68	72	70	59	RMT-8
CRVT/8-500	400-50/60	690	180		0,65	4110	49	53	60	28	RMT-1,5
CRVT/8-560	400-50/60	650	240		0,7	5270	51	54	60	32	RMT-1,5
CRVT/8-630	400-50/60	635	300		0,7	7110	53	57	70	53	RMT-1,5
CRVT/8-710	400-50/60	617	866		2,08	11285	61	66	60	79	RMT-3,5

* Three phase speed controllers (RMT) are suitable for 400V.





Acoustic characteristics CRHB/CRHT

Sound power spectrum in dB(A), at the fan inlet and outlet, at 3 working points of the performance curve (A: maximum volume)

Model CRHB/2-225		63	125	250	500	1000	2000	4000	8000
Inlet	A	42	58	65	72	72	71	71	66
	B	39	53	60	66	66	65	66	59
	C	39	53	59	68	67	65	61	56
Outlet	A	45	60	67	74	77	78	78	69
	B	42	55	63	69	72	73	73	62
	C	40	54	62	68	71	72	72	62

Model CRHB/4-225		63	125	250	500	1000	2000	4000	8000
Inlet	A	39	48	57	60	60	60	60	51
	B	35	44	53	56	56	57	56	46
	C	34	42	51	56	55	52	49	43
Outlet	A	38	48	56	62	65	66	61	50
	B	37	46	55	60	63	64	59	48
	C	34	43	52	57	60	61	56	45

Model CRHB/2-250		63	125	250	500	1000	2000	4000	8000
Inlet	A	43	59	65	72	73	71	71	67
	B	40	53	61	66	66	65	67	60
	C	40	54	60	69	68	66	62	57
Outlet	A	45	61	68	74	77	78	78	70
	B	42	55	64	69	72	73	73	63
	C	41	55	63	69	72	73	73	63

Model CRHB/4-250		63	125	250	500	1000	2000	4000	8000
Inlet	A	39	48	57	60	60	60	60	51
	B	38	47	56	59	59	60	59	49
	C	39	47	57	61	60	58	54	49
Outlet	A	38	48	56	62	65	66	61	50
	B	36	46	55	60	63	64	59	48
	C	33	43	52	57	60	61	56	44

Model CRHB/4-280		63	125	250	500	1000	2000	4000	8000
Inlet	A	38	47	56	59	59	60	59	49
	B	34	43	52	55	55	56	55	45
	C	32	40	50	54	53	51	47	42
Outlet	A	37	47	55	61	64	65	60	48
	B	36	46	54	59	62	63	58	46
	C	32	42	50	56	59	60	54	42

Model CRHB/4-315		63	125	250	500	1000	2000	4000	8000
Inlet	A	41	59	67	67	67	64	60	50
	B	41	58	66	66	66	64	59	49
	C	39	56	64	64	64	62	57	47
Outlet	A	44	60	69	71	73	72	65	55
	B	42	59	67	69	71	70	63	53
	C	42	57	65	67	69	68	61	51

Model CRHT/4-315		63	125	250	500	1000	2000	4000	8000
Inlet	A	41	59	68	68	67	65	61	51
	B	41	58	67	67	67	64	60	50
	C	39	56	65	65	65	62	58	48
Outlet	A	44	61	70	72	74	73	65	56
	B	43	59	68	70	72	71	64	54
	C	40	57	66	68	70	69	62	52

Model CRHB/6-315		63	125	250	500	1000	2000	4000	8000
Inlet	A	38	53	57	58	58	55	48	38
	B	38	53	56	57	57	55	48	38
	C	36	50	54	56	55	53	46	36
Outlet	A	40	54	58	62	65	60	52	43
	B	38	52	56	61	63	58	51	41
	C	37	51	55	59	61	57	49	40

Model CRHT/6-315		63	125	250	500	1000	2000	4000	8000
Inlet	A	38	53	56	58	57	55	48	38
	B	38	53	56	57	57	55	48	38
	C	36	50	54	55	55	53	46	35
Outlet	A	40	54	58	62	64	60	52	43
	B	38	52	56	61	63	58	51	41
	C	37	51	55	59	61	57	49	40

Model CRHB/4-355		63	125	250	500	1000	2000	4000	8000
Inlet	A	47	62	67	71	71	73	76	67
	B	45	59	64	68	69	71	74	64
	C	45	59	64	68	69	71	74	64
Outlet	A	52	68	74	78	79	79	77	67
	B	48	64	69	73	75	74	73	62
	C	47	62	66	69	72	73	73	61

Model CRHT/4-355		63	125	250	500	1000	2000	4000	8000
Inlet	A	47	63	68	71	72	74	77	69
	B	45	61	66	69	70	72	75	67
	C	45	61	66	69	70	72	75	67
Outlet	A	53	70	75	79	80	80	78	69
	B	49	66	71	75	77	76	75	65
	C	48	64	68	71	74	75	75	64

Model CRHB/6-355		63	125	250	500	1000	2000	4000	8000
Inlet	A	43	55	60	64	65	69	70	52
	B	43	54	59	62	64	68	69	51
	C	42	53	58	62	64	68	68	50
Outlet	A	47	59	65	69	70	69	65	54
	B	44	56	62	66	67	67	62	51
	C	45	55	58	63	66	67	62	49

Model CRHT/6-355		63	125	250	500	1000	2000	4000	8000
Inlet	A	43	55	60	63	65	69	70	52
	B	43	54	59	62	64	68	69	51
	C	42	53	58	62	64	68	68	50
Outlet	A	47	59	64	68	70	69	64	53
	B	44	56	61	66	67	66	61	50
	C	45	55	58	63	66	67	62	49

Model CRHB/4-400		63	125	250	500	1000	2000	4000	8000
Inlet	A	47	63	67	71	72	74	77	68
	B	45	60	65	69	70	72	75	66
	C	45	60	65	69	70	72	75	66
Outlet	A	53	69	75	79	80	80	78	68
	B	49	65	71	75	76	76	74	64
	C	48	64	67	70	73	74	74	63

Model CRHT/4-400		63	125	250	500	1000	2000	4000	8000
Inlet	A	46	61	66	70	71	73	76	65
	B	45	59	64	68	69	71	74	64
	C	45	59	64	68	69	71	74	63
Outlet	A	52	67	73	77	78	78	76	66
	B	48	64	69	73	75	74	73	62
	C	47	62	66	69	72	73	73	61

Model CRHB/6-400		63	125	250	500	1000	2000	4000	8000
Inlet	A	43	55	60	64	65	69	71	53
	B	43	54	59	62	64	68	69	51
	C	42	54	59	62	64	68	69	51
Outlet	A	47	59	65	69	70	70	65	54
	B	44	56	62	66	67	67	62	51
	C	45	55	59	64	67	68	63	50

Model CRHT/6-400		63	125	250	500	1000	2000	4000	8000
Inlet	A	43	55	60	64	65	69	71	53
	B	42	54	59	63	64	68	70	52
	C	42	54	59	62	64	68	69	51
Outlet	A	47	60	65	69	71	70	66	55
	B	44	57	62	66	68	67	63	52
	C	45	55	59	64	67	68	63	50

Model CRHB/4-450		63	125	250	500	1000	2000	4000	8000
Inlet	A	54	73	77	80	81	79	80	78
	B	54	70	74	76	76	74	72	68
	C	53	67	71	73	73	71	68	63
Outlet	A	58	77	83	85	85	84	85	83
	B	57	74	78	81	82	80	78	74
	C	54	71	75	78	79	77	75	71

Model CRHT/4-450		63	125	250	500	1000	2000	4000	8000
Inlet	A	53	72	76	79	79	78	79	75
	B	52	68	72	74	74	72	71	65
	C	52	66	69	72	71	69	66	61
Outlet	A	57	77	81	83	82	83	83	81
	B	55	72	76	79	80	78	76	72
	C	53	69	73	77	77	76	73	69

Model CRHB/6-450		63	125	250	500	1000	2000	4000	800
------------------	--	----	-----	-----	-----	------	------	------	-----

■ Acoustic characteristics CRHB/CRHT

Sound power spectrum in dB(A), at the fan inlet and outlet, at 3 working points of the performance curve (A: maximum volume)

Model CRHB/4-500		63	125	250	500	1000	2000	4000	8000
Inlet	A	57	76	80	83	84	82	83	81
	B	57	73	77	79	79	77	75	71
	C	56	70	74	76	76	74	71	66
Outlet	A	61	80	86	88	88	87	88	86
	B	60	77	81	84	85	83	81	77
	C	57	74	78	81	82	80	78	74

Model CRHT/4-500		63	125	250	500	1000	2000	4000	8000
Inlet	A	56	75	79	82	82	81	82	78
	B	55	71	75	77	77	75	74	68
	C	55	69	72	75	74	72	69	64
Outlet	A	60	80	84	86	85	86	86	84
	B	58	75	79	82	83	81	79	75
	C	56	72	76	80	80	79	76	72

Model CRHB/6-500		63	125	250	500	1000	2000	4000	8000
Inlet	A	55	65	69	72	72	72	75	63
	B	52	60	64	66	66	64	66	49
	C	50	58	62	64	64	62	58	53
Outlet	A	56	69	73	75	76	77	77	66
	B	55	64	68	71	72	71	68	58
	C	53	62	66	69	70	68	66	56

Model CRHT/6-500		63	125	250	500	1000	2000	4000	8000
Inlet	A	55	65	69	72	72	72	75	63
	B	53	61	65	67	67	65	67	50
	C	50	59	62	65	64	62	59	54
Outlet	A	56	69	73	75	76	77	77	66
	B	55	64	69	72	73	71	69	59
	C	53	62	67	70	70	69	67	57

Model CRHB/8-500		63	125	250	500	1000	2000	4000	8000
Inlet	A	50	58	62	65	66	67	66	53
	B	47	54	57	60	59	59	56	37
	C	44	51	54	57	56	54	51	46
Outlet	A	53	61	64	67	68	70	70	52
	B	49	56	61	64	64	63	61	47
	C	47	54	59	62	63	61	59	45

Model CRHT/8-500		63	125	250	500	1000	2000	4000	8000
Inlet	A	49	57	61	64	64	67	64	51
	B	44	51	55	57	57	58	52	33
	C	42	49	52	55	55	52	49	44
Outlet	A	53	59	63	65	67	69	68	49
	B	46	54	59	62	62	61	57	43
	C	45	53	57	60	61	60	56	42

Model CRHB/6-560		63	125	250	500	1000	2000	4000	8000
Inlet	A	55	65	70	73	73	72	75	64
	B	53	62	65	68	67	65	67	51
	C	50	59	63	65	65	63	60	54
Outlet	A	57	70	74	76	76	77	78	67
	B	55	65	69	73	73	72	69	60
	C	53	63	67	70	71	69	67	57

Model CRHT/4-560		63	125	250	500	1000	2000	4000	8000
Inlet	A	57	76	80	83	83	82	82	80
	B	56	73	76	79	78	76	75	70
	C	56	70	74	76	76	74	71	65
Outlet	A	61	80	85	88	87	87	87	86
	B	59	76	81	84	84	83	81	76
	C	57	73	78	81	82	80	78	73

Model CRHT/6-560		63	125	250	500	1000	2000	4000	8000
Inlet	A	55	65	69	72	73	72	75	64
	B	53	61	65	67	67	65	67	50
	C	50	59	62	65	64	62	59	54
Outlet	A	56	70	73	75	76	77	77	67
	B	55	64	69	72	73	71	69	59
	C	53	62	67	70	70	69	67	57

Model CRHB/8-560		63	125	250	500	1000	2000	4000	8000
Inlet	A	51	59	63	66	66	68	67	54
	B	46	53	57	59	59	59	55	36
	C	44	51	54	57	56	54	51	46
Outlet	A	53	61	65	67	69	70	71	53
	B	48	56	60	64	64	63	60	46
	C	47	54	59	62	63	61	59	45

Model CRHT/8-560		63	125	250	500	1000	2000	4000	8000
Inlet	A	49	57	61	64	64	67	64	51
	B	44	51	55	57	57	58	52	33
	C	42	49	52	55	55	52	49	44
Outlet	A	53	59	63	65	67	69	68	49
	B	46	54	59	62	62	61	57	43
	C	45	53	57	60	61	60	56	42

Model CRHB/6-630		63	125	250	500	1000	2000	4000	8000
Inlet	A	55	66	70	73	73	72	76	64
	B	53	62	65	68	67	65	67	51
	C	50	59	63	65	65	63	60	55
Outlet	A	57	70	74	76	76	78	78	68
	B	55	65	69	73	73	72	69	60
	C	53	63	67	71	71	70	67	58

Model CRHT/6-630		63	125	250	500	1000	2000	4000	8000
Inlet	A	55	66	70	73	73	72	76	64
	B	53	62	65	68	68	66	68	52
	C	50	59	63	65	65	63	60	55
Outlet	A	57	70	74	76	76	78	78	68
	B	55	65	70	73	73	72	70	60
	C	53	63	67	71	71	70	67	58

Model CRHB/8-630		63	125	250	500	1000	2000	4000	8000
Inlet	A	52	60	64	67	67	69	69	55
	B	49	56	59	62	61	60	59	40
	C	46	53	57	59	59	57	54	49
Outlet	A	54	63	66	69	70	72	72	55
	B	51	58	63	66	67	65	63	50
	C	49	57	61	65	65	64	61	49

Model CRHT/8-630		63	125	250	500	1000	2000	4000	8000
Inlet	A	52	59	63	66	67	68	68	55
	B	48	55	59	61	61	60	58	39
	C	46	52	56	59	58	56	53	48
Outlet	A	54	62	66	68	70	71	71	55
	B	50	58	62	65	66	65	62	49
	C	49	56	61	64	64	63	61	48

Model CRHT/6-710		63	125	250	500	1000	2000	4000	8000
Inlet	A	55	66	71	74	74	73	76	66
	B	54	63	67	69	69	67	69	53
	C	50	60	64	66	66	64	61	56
Outlet	A	57	72	75	77	77	79	79	70
	B	56	67	71	74	75	74	71	62
	C	53	64	68	71	72	71	68	59

Model CRHT/8-710		63	125	250	500	1000	2000	4000	8000
Inlet	A	49	60	64	67	68	67	70	59
	B	47	57	61	63	63	61	62	47
	C	44	54	58	60	60	58	54	49
Outlet	A	51	65	69	71	71	72	73	63
	B	50	60	65	68	69	67	65	56
	C	47	57	62	65	66	64	62	53





Acoustic characteristics CRVB/CRVT

Sound power spectrum in dB(A), at the fan inlet and outlet, at 3 working points of the performance curve (A: maximum volume)

Model CRVB/2-225		63	125	250	500	1000	2000	4000	8000
Inlet	A	41	57	64	71	71	70	70	65
	B	38	52	59	65	65	64	65	58
	C	39	53	59	68	67	65	61	56
Outlet	A	43	58	65	72	75	76	76	67
	B	40	53	61	67	70	71	71	60
	C	39	53	61	67	70	71	71	61

Model CRVB/4-225		63	125	250	500	1000	2000	4000	8000
Inlet	A	38	47	56	59	59	59	59	50
	B	34	43	52	55	55	55	56	45
	C	34	42	51	56	55	52	49	43
Outlet	A	36	46	54	60	63	64	59	48
	B	35	44	53	58	61	62	57	46
	C	33	42	51	56	59	60	55	44

Model CRVB/2-250		63	125	250	500	1000	2000	4000	8000
Inlet	A	42	58	64	71	72	70	70	66
	B	39	52	60	65	65	64	66	59
	C	40	54	60	69	68	66	62	57
Outlet	A	43	59	66	72	75	76	76	68
	B	40	53	62	67	70	71	71	61
	C	40	54	62	68	71	72	72	62

Model CRVB/4-250		63	125	250	500	1000	2000	4000	8000
Inlet	A	38	47	56	59	59	59	59	50
	B	37	46	55	58	58	59	58	48
	C	39	47	57	61	60	58	54	49
Outlet	A	36	46	54	60	63	64	59	48
	B	34	44	53	58	61	62	57	46
	C	31	42	51	56	59	60	55	43

Model CRVB/4-280		63	125	250	500	1000	2000	4000	8000
Inlet	A	37	46	55	58	58	59	58	48
	B	33	42	51	54	54	55	54	44
	C	32	40	50	54	53	51	47	42
Outlet	A	35	45	53	59	62	63	58	46
	B	34	44	52	57	60	61	56	46
	C	31	41	49	55	58	59	53	41

Model CRVB/6-250		63	125	250	500	1000	2000	4000	8000
Inlet	A	42	58	64	71	72	70	70	66
	B	39	52	60	65	65	64	66	59
	C	40	54	60	69	68	66	62	57
Outlet	A	43	59	66	72	75	76	76	68
	B	40	53	62	67	70	71	71	61
	C	40	54	62	68	71	72	72	62

Model CRVB/4-315		63	125	250	500	1000	2000	4000	8000
Inlet	A	40	58	66	66	66	63	59	49
	B	40	57	65	65	65	63	58	48
	C	39	56	64	64	64	62	57	47
Outlet	A	42	58	67	69	71	70	63	52
	B	40	57	65	67	69	68	61	51
	C	39	56	64	66	68	67	60	50

Model CRVT/4-315		63	125	250	500	1000	2000	4000	8000
Inlet	A	40	58	67	67	66	64	60	50
	B	40	57	66	66	66	63	59	49
	C	39	56	65	65	65	62	58	48
Outlet	A	42	59	68	70	72	71	63	54
	B	41	57	66	68	70	69	62	52
	C	39	56	65	67	69	68	61	51

Model CRVB/6-315		63	125	250	500	1000	2000	4000	8000
Inlet	A	37	52	56	57	57	54	47	37
	B	37	52	55	56	56	54	47	37
	C	36	50	54	56	55	53	46	36
Outlet	A	38	52	56	60	63	58	50	41
	B	36	50	54	59	61	56	49	39
	C	36	50	54	58	60	56	48	39

Model CRVT/6-315		63	125	250	500	1000	2000	4000	8000
Inlet	A	37	52	55	57	56	54	47	37
	B	37	52	55	56	56	54	47	37
	C	36	50	54	55	55	53	46	35
Outlet	A	38	52	56	60	62	58	50	41
	B	36	50	54	59	61	56	49	39
	C	36	50	54	58	60	56	48	39

Model CRVB/4-355		63	125	250	500	1000	2000	4000	8000
Inlet	A	46	61	66	70	70	72	75	66
	B	44	58	63	67	68	70	73	63
	C	45	59	64	68	69	71	74	64
Outlet	A	50	66	72	76	77	77	75	65
	B	46	62	67	71	73	72	71	60
	C	46	61	65	68	71	72	72	60

Model CRVT/4-355		63	125	250	500	1000	2000	4000	8000
Inlet	A	46	62	67	70	71	73	76	68
	B	44	60	65	68	69	71	74	66
	C	45	61	66	69	70	72	75	67
Outlet	A	51	68	73	77	78	78	76	67
	B	47	64	69	73	75	74	73	63
	C	47	63	67	70	73	74	74	63

Model CRVB/6-355		63	125	250	500	1000	2000	4000	8000
Inlet	A	42	54	59	63	64	68	69	51
	B	42	53	58	61	63	67	68	50
	C	42	53	58	62	64	68	68	50
Outlet	A	45	57	63	67	68	67	63	52
	B	42	54	60	64	65	65	60	49
	C	44	54	57	62	65	66	61	48

Model CRVT/6-355		63	125	250	500	1000	2000	4000	8000
Inlet	A	42	54	59	62	64	68	69	51
	B	42	53	58	61	63	67	68	50
	C	42	53	58	62	64	68	68	50
Outlet	A	45	57	62	66	68	67	62	51
	B	42	54	59	64	65	64	59	48
	C	44	54	57	62	65	66	61	48

Model CRVB/4-400		63	125	250	500	1000	2000	4000	8000
Inlet	A	46	62	66	70	71	73	76	67
	B	44	59	64	68	69	71	74	65
	C	45	60	65	69	70	72	75	66
Outlet	A	51	67	73	77	78	78	76	66
	B	47	63	69	73	74	74	72	62
	C	47	63	66	69	72	73	73	62

Model CRVT/4-400		63	125	250	500	1000	2000	4000	8000
Inlet	A	45	60	65	69	70	72	75	64
	B	44	58	63	67	68	70	73	63
	C	45	59	64	68	69	71	74	63
Outlet	A	50	65	71	75	76	76	74	64
	B	46	62	67	71	73	72	71	60
	C	46	61	65	68	71	72	72	60

Model CRVB/6-400		63	125	250	500	1000	2000	4000	8000
Inlet	A	42	54	59	63	64	68	70	52
	B	42	53	58	61	63	67	68	50
	C	42	54	59	62	64	68	69	51
Outlet	A	45	57	63	67	68	68	63	52
	B	42	54	60	64	65	65	60	49
	C	44	54	58	63	66	67	62	49

Model CRVT/6-400		63	125	250	500	1000	2000	4000	8000
Inlet	A	42	54	59	63	64	68	70	52
	B	41	53	58	62	63	67	69	51
	C	42	54	59	62	64	68	69	51
Outlet	A	45	58	63	67	69	68	64	53
	B	42	55	60	64	66	65	61	50
	C	44	54	58	63	66	67	62	49

Model CRVB/4-450		63	125	250	500	1000	2000	4000	8000
Inlet	A	53	72	76	79	80	78	79	77
	B	53	69	73	75	75	73	71	67
	C	53	67	71	73	73	71	68	63
Outlet	A	56	75	81	83	83	82	83	81
	B	55	72	76	79	80	78	76	72
	C	53	70	74	77	78	76	74	70

Model CRVT/4-450		63	125	250	500	1000	2000	4000
------------------	--	----	-----	-----	-----	------	------	------

■ Acoustic characteristics CRVB/CRVT

Sound power spectrum in dB(A), at the fan inlet and outlet, at 3 working points of the performance curve (A: maximum volume)

Model CRVB/4-500		63	125	250	500	1000	2000	4000	8000
Inlet	A	56	75	79	82	83	81	82	80
	B	56	72	76	78	78	76	74	70
	C	56	70	74	76	76	74	71	66
Outlet	A	59	78	84	86	86	85	86	84
	B	58	75	79	82	83	81	79	75
	C	56	73	77	80	81	79	77	73

Model CRVB/6-500		63	125	250	500	1000	2000	4000	8000
Inlet	A	54	64	68	71	71	71	74	62
	B	51	59	63	65	65	63	65	48
	C	50	58	62	64	64	62	58	53
Outlet	A	54	67	71	73	74	75	75	64
	B	53	62	66	69	70	69	66	56
	C	52	61	65	68	69	67	65	55

Model CRVB/8-500		63	125	250	500	1000	2000	4000	8000
Inlet	A	49	57	61	64	65	66	65	52
	B	46	53	56	59	58	58	55	36
	C	44	51	54	57	56	54	51	46
Outlet	A	51	59	62	65	66	68	68	50
	B	47	54	59	62	62	61	59	45
	C	46	53	58	61	62	60	58	4

Model CRVB/6-560		63	125	250	500	1000	2000	4000	8000
Inlet	A	54	64	69	72	72	71	74	63
	B	52	61	64	67	66	64	66	50
	C	49	58	62	64	64	62	59	53
Outlet	A	55	68	72	74	74	75	76	65
	B	53	63	67	71	71	70	67	58
	C	52	62	66	69	70	68	66	56

Model CRVB/8-560		63	125	250	500	1000	2000	4000	8000
Inlet	A	50	58	62	65	65	67	66	53
	B	45	52	56	58	58	58	54	35
	C	44	51	54	57	56	54	51	46
Outlet	A	51	59	63	65	67	68	69	51
	B	46	54	58	62	62	61	58	44
	C	46	53	58	61	62	60	58	44

Model CRVB/6-630		63	125	250	500	1000	2000	4000	8000
Inlet	A	54	65	69	72	72	71	75	63
	B	52	61	64	67	66	64	66	50
	C	50	59	63	65	65	63	60	55
Outlet	A	55	68	72	74	74	76	76	66
	B	53	63	67	71	71	70	67	58
	C	52	62	66	70	70	69	66	57

Model CRVB/8-630		63	125	250	500	1000	2000	4000	8000
Inlet	A	51	59	63	66	66	68	68	54
	B	48	55	58	61	60	59	58	39
	C	46	53	57	59	59	57	54	49
Outlet	A	52	61	64	67	68	70	70	53
	B	59	56	61	64	65	63	61	48
	C	48	56	60	64	64	63	60	48

Model CRVT/4-500		63	125	250	500	1000	2000	4000	8000
Inlet	A	55	74	78	81	81	80	81	77
	B	54	70	74	76	77	74	73	67
	C	55	69	72	75	74	72	69	64
Outlet	A	58	78	82	84	83	84	84	82
	B	56	73	77	80	81	79	77	73
	C	55	71	75	79	79	78	75	71

Model CRVT/6-500		63	125	250	500	1000	2000	4000	8000
Inlet	A	54	64	68	71	71	71	74	62
	B	52	60	64	66	66	64	66	49
	C	50	59	62	65	64	62	59	54
Outlet	A	54	67	71	73	73	75	75	64
	B	53	62	67	70	71	69	67	57
	C	52	61	66	69	69	68	66	56

Model CRVT/8-500		63	125	250	500	1000	2000	4000	8000
Inlet	A	48	56	60	63	63	66	63	50
	B	43	50	54	56	56	57	51	32
	C	42	49	52	55	55	52	49	44
Outlet	A	51	57	61	63	65	67	66	47
	B	44	52	57	60	60	59	55	41
	C	44	52	56	59	60	59	55	41

Model CRVT/4-560		63	125	250	500	1000	2000	4000	8000
Inlet	A	56	75	79	82	82	81	81	79
	B	55	72	75	78	77	75	74	69
	C	56	70	74	76	76	74	71	65
Outlet	A	59	78	83	86	85	85	85	84
	B	57	74	79	82	82	81	79	74
	C	56	72	77	80	81	79	77	72

Model CRVT/6-560		63	125	250	500	1000	2000	4000	8000
Inlet	A	54	64	68	71	72	71	74	63
	B	52	60	64	66	66	64	66	49
	C	50	59	62	65	64	62	59	54
Outlet	A	54	68	71	73	74	75	75	65
	B	53	62	67	70	71	69	67	57
	C	52	61	66	69	69	68	66	56

Model CRVT/8-560		63	125	250	500	1000	2000	4000	8000
Inlet	A	48	56	60	63	63	66	63	50
	B	43	50	54	56	56	57	51	32
	C	42	49	52	55	55	52	49	44
Outlet	A	51	57	61	63	65	67	66	47
	B	44	52	57	60	60	59	55	41
	C	44	52	56	59	60	59	55	41

Model CRVT/6-630		63	125	250	500	1000	2000	4000	8000
Inlet	A	54	65	69	72	72	71	75	63
	B	52	61	64	67	67	65	67	51
	C	50	59	63	65	65	63	60	55
Outlet	A	55	68	72	74	74	76	76	66
	B	53	63	67	71	71	70	68	58
	C	52	62	66	70	70	69	66	57

Model CRVT/8-630		63	125	250	500	1000	2000	4000	8000
Inlet	A	51	58	62	65	66	67	67	54
	B	47	54	58	60	60	59	57	38
	C	46	52	56	59	58	56	53	48
Outlet	A	52	60	64	66	68	69	69	53
	B	48	56	60	63	64	63	60	47
	C	48	55	60	63	63	62	60	47

Model CRVT/6-710		63	125	250	500	1000	2000	4000	8000
Inlet	A	54	65	70	73	73	72	75	65
	B	53	62	66	68	68	66	68	52
	C	50	60	64	66	66	64	61	56
Outlet	A	55	70	73	75	75	77	77	68
	B	54	65	69	72	73	72	69	60
	C	52	63	67	70	71	70	67	58

Model CRVT/8-710		63	125	250	500	1000	2000	4000	8000
Inlet	A	48	59	63	66	67	66	69	58
	B	46	56	60	62	62	60	61	46
	C	44	54	58	60	60	58	54	49
Outlet	A	49	63	67	69	69	70	71	61
	B	48	58	63	66	67	65	63	54
	C	46	56	61	64	65	63	61	52



■ Performance curves CRHB/CRHT

The values are sound pressure levels measured at 1,5 m, in free field conditions, at the fan inlet (black) and outlet (blue).

CRHB/CRHT

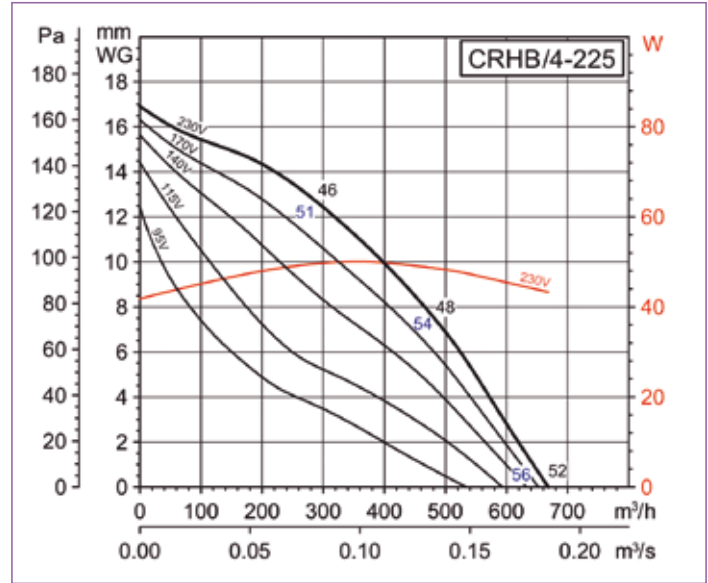
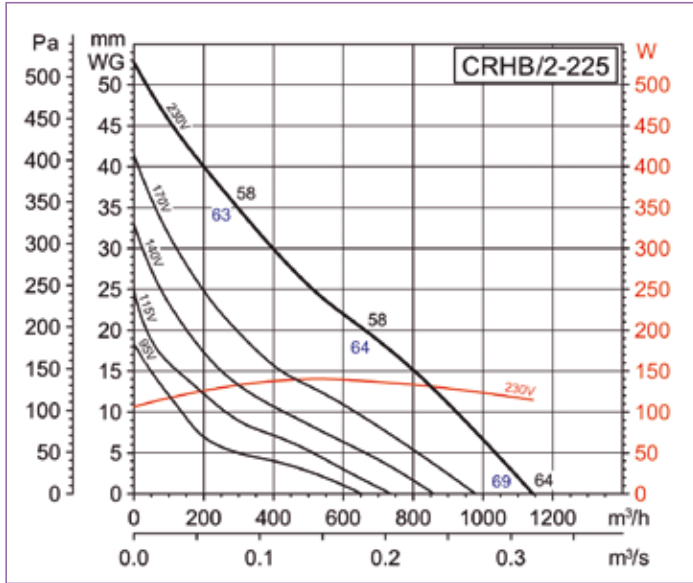

Roof mounted fans

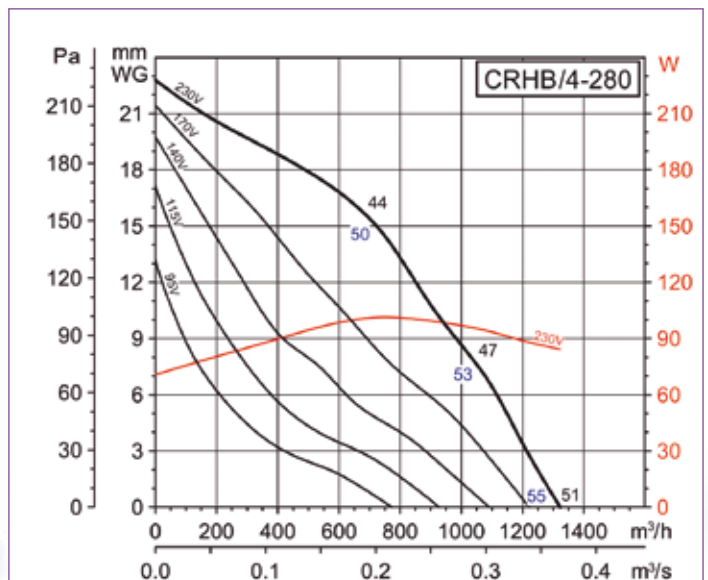
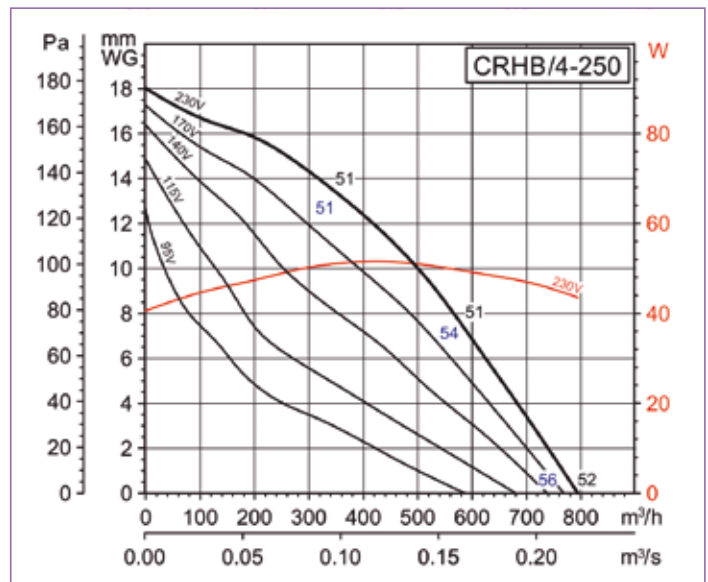
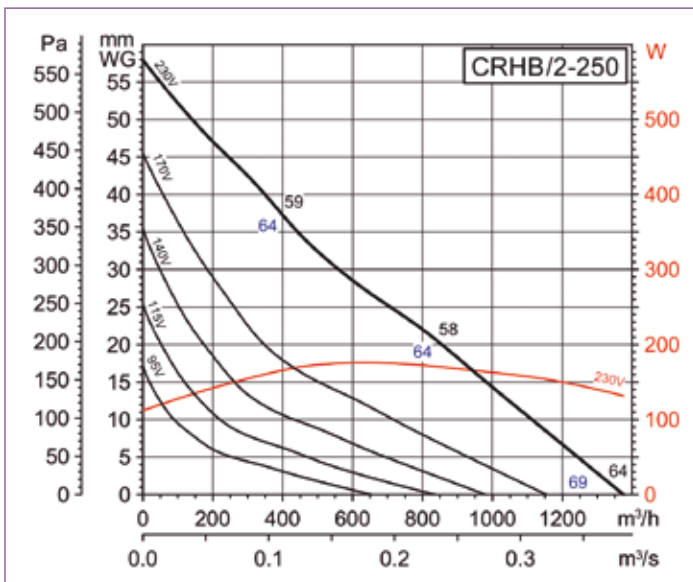

■ Performance curves CRHB/CRHT

The values are sound pressure levels measured at 1,5 m, in free field conditions, at the fan inlet (black) and outlet (blue).

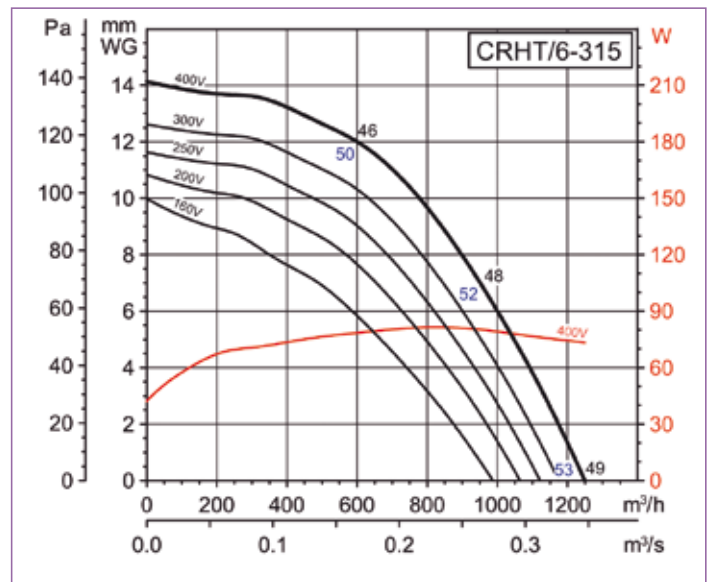
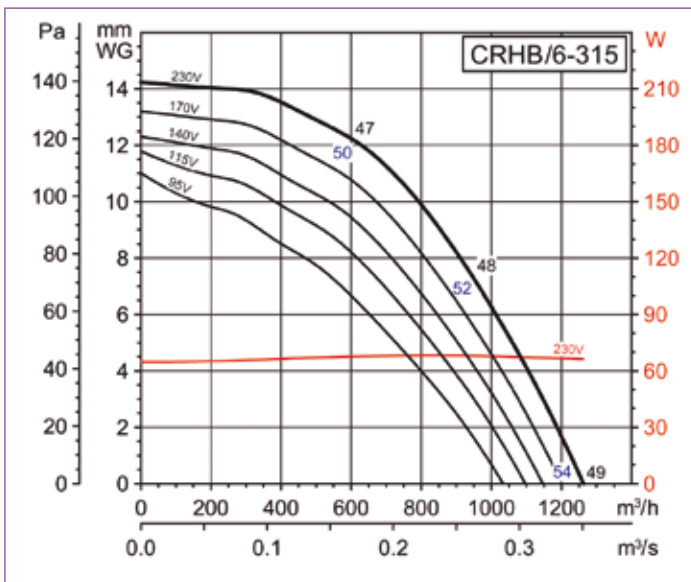
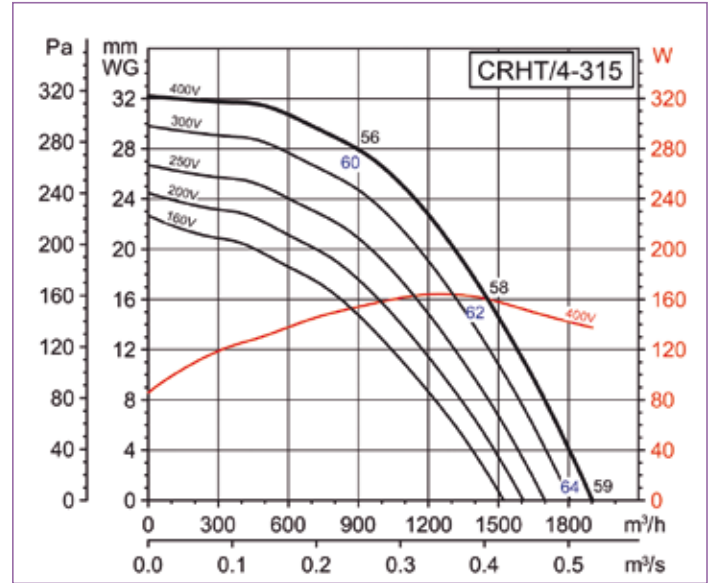
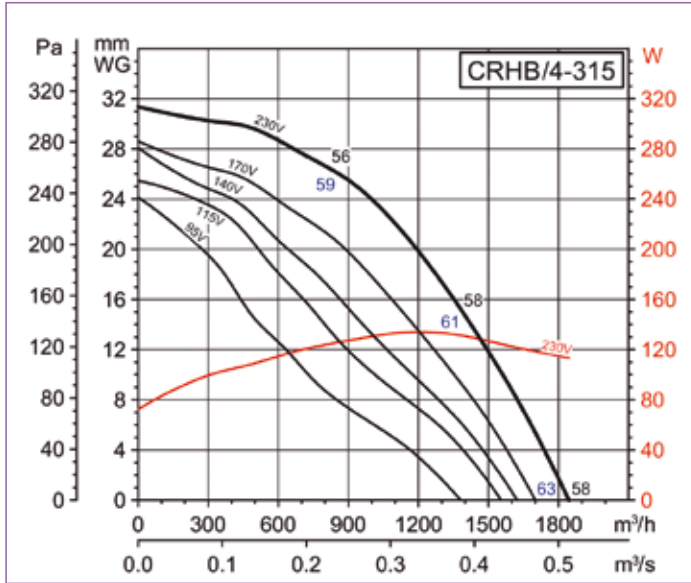

Performance curves CRHB/CRHT

The values are sound pressure levels measured at 1,5 m, in free field conditions, at the fan inlet (black) and outlet (blue).

CRHB/CRHT

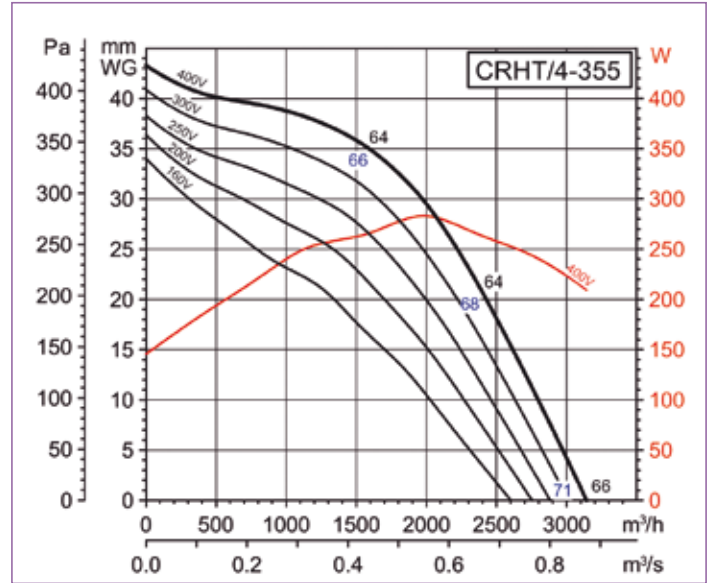
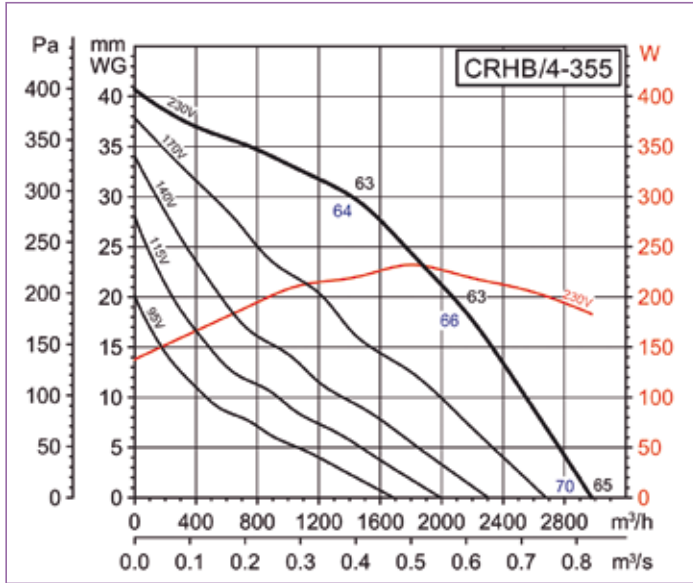

Roof mounted fans

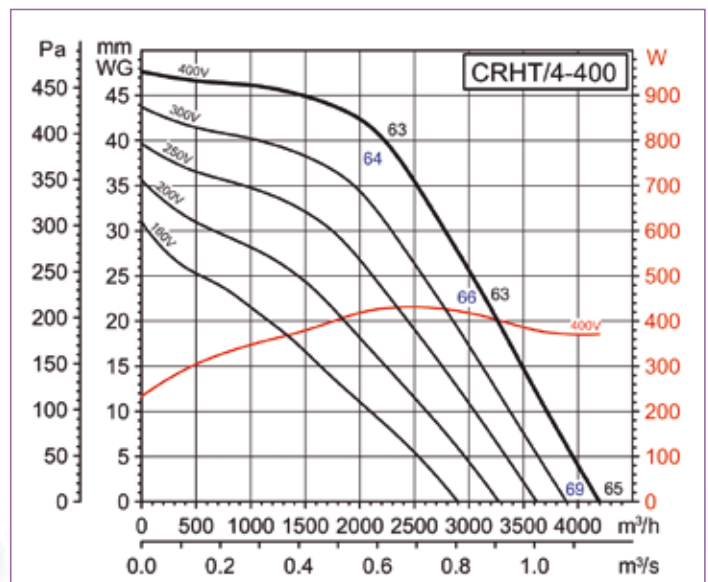
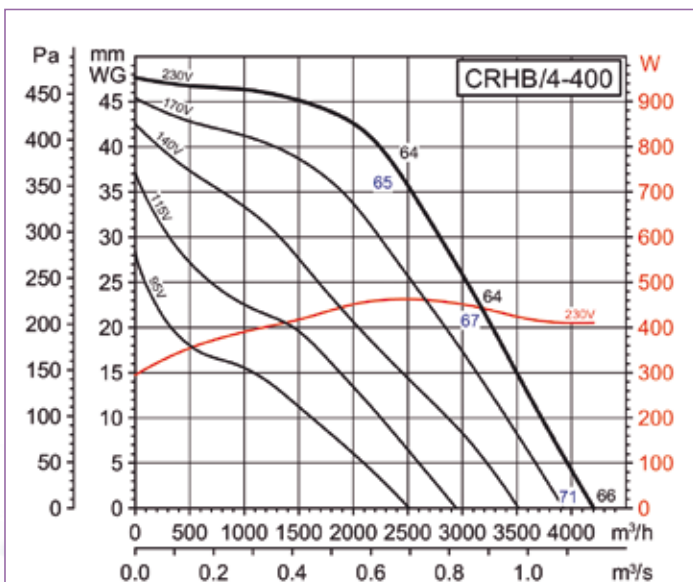
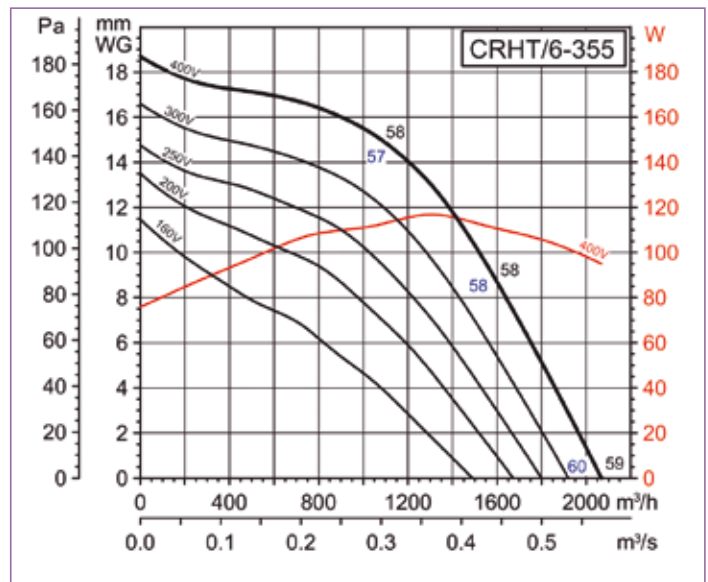
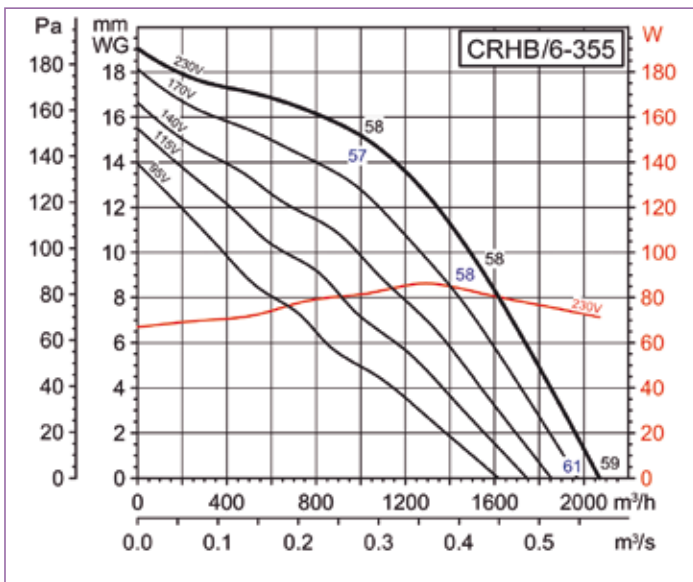

■ Performance curves CRHB/CRHT

The values are sound pressure levels measured at 1,5 m, in free field conditions, at the fan inlet (black) and outlet (blue).

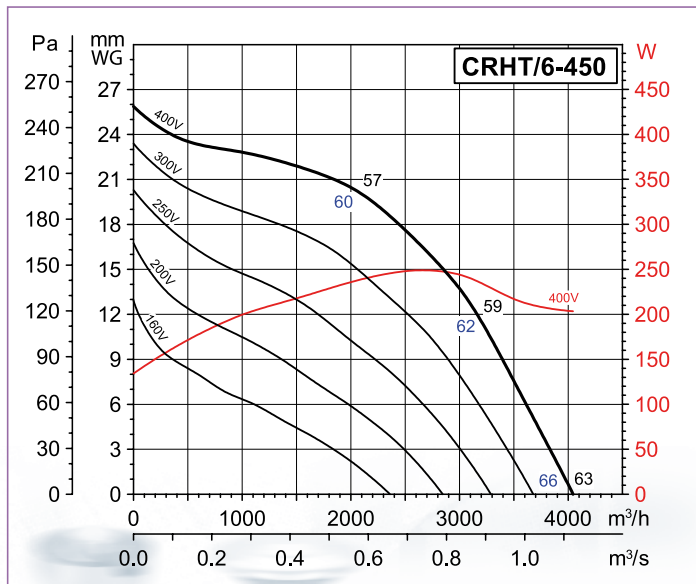
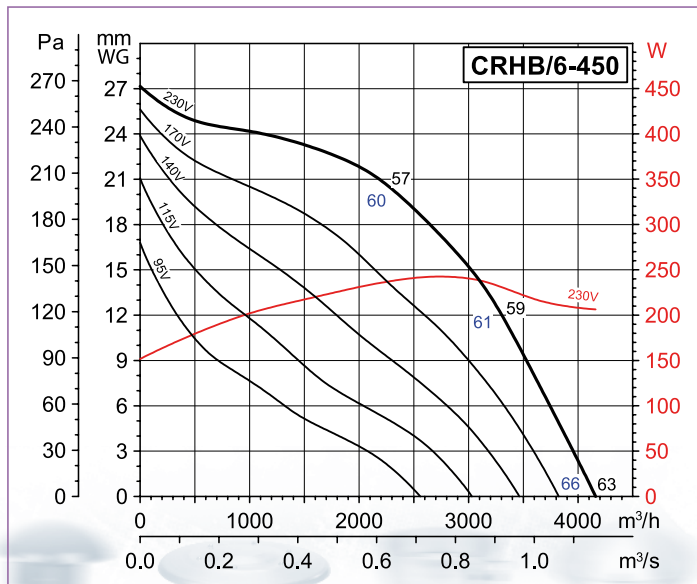
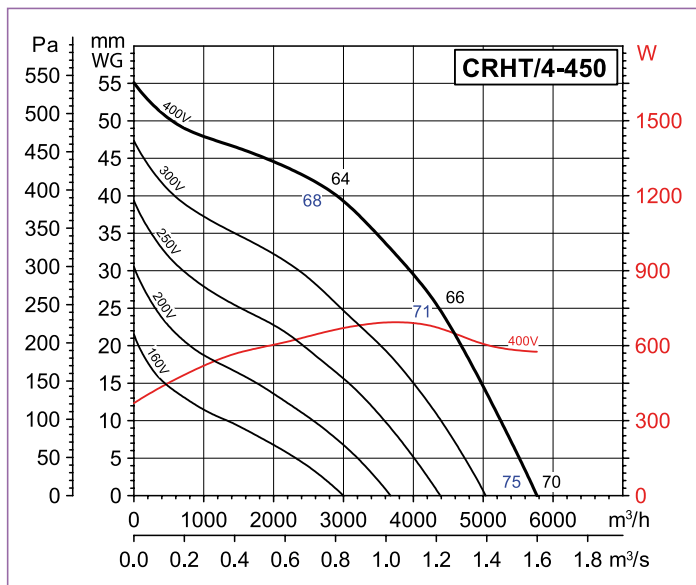
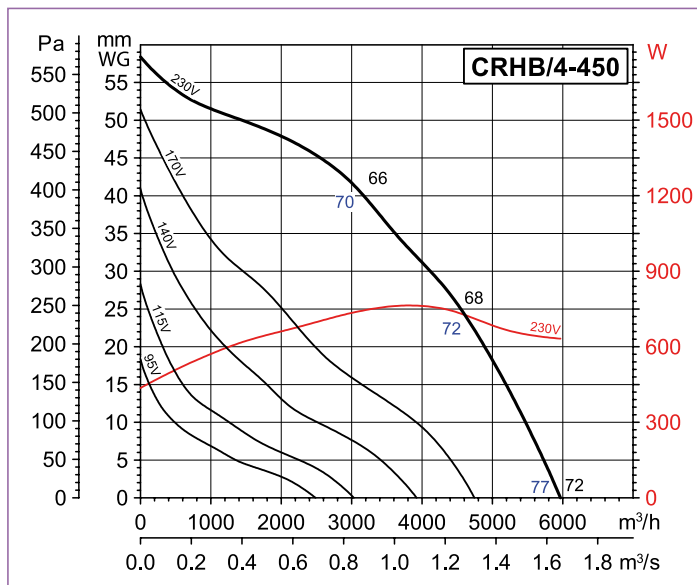
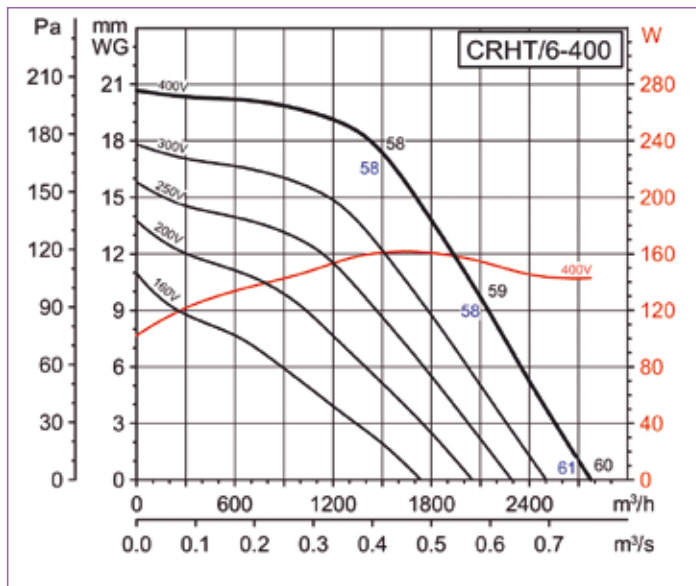
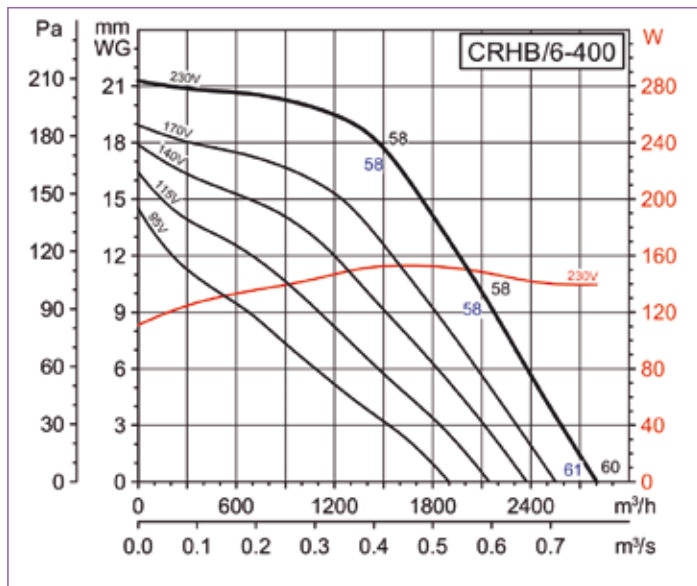

■ Performance curves CRHB/CRHT

The values are sound pressure levels measured at 1,5 m, in free field conditions, at the fan inlet (black) and outlet (blue).

CRHB/CRHT

Roof mounted fans

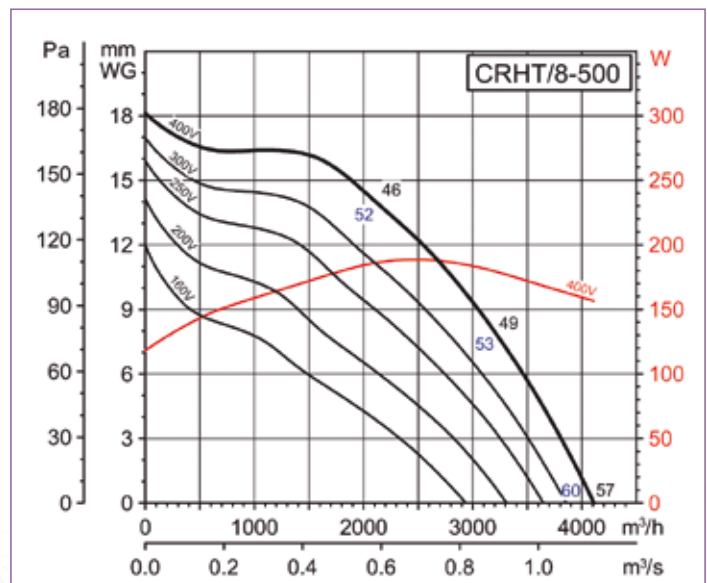
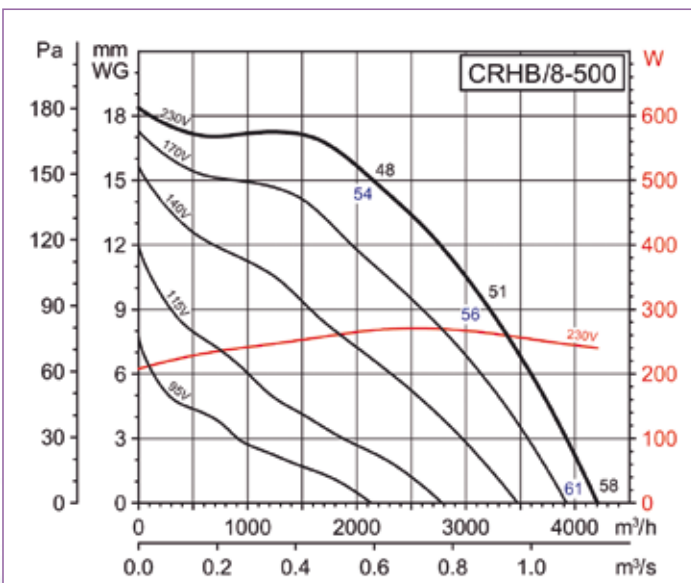
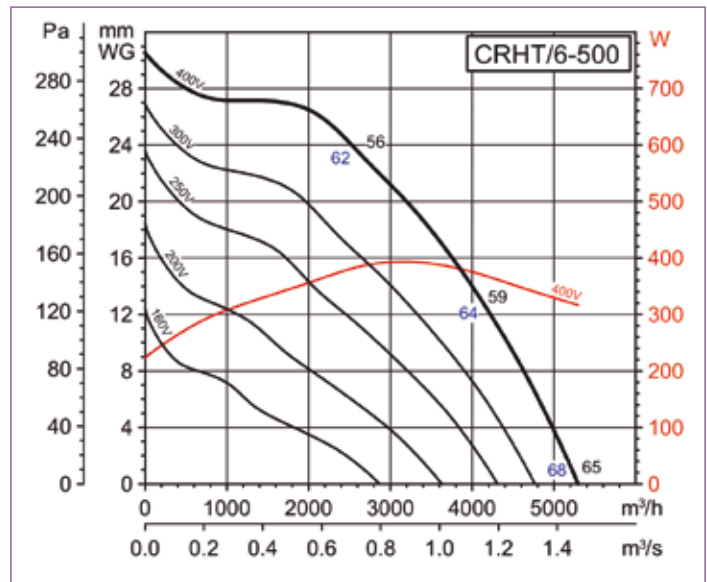
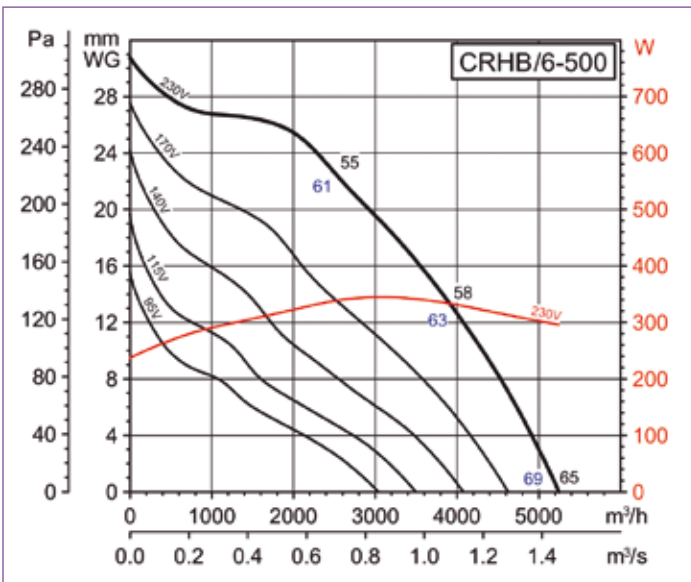
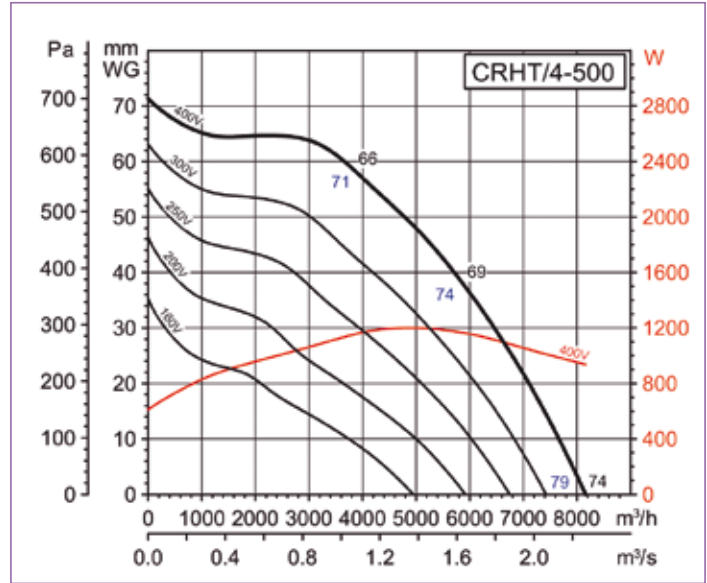
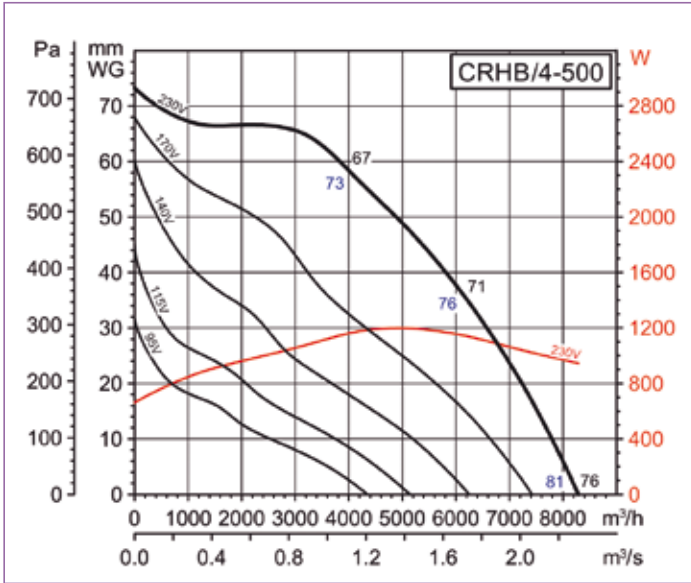

■ Performance curves CRHB/CRHT

The values are sound pressure levels measured at 1,5 m, in free field conditions, at the fan inlet (black) and outlet (blue).

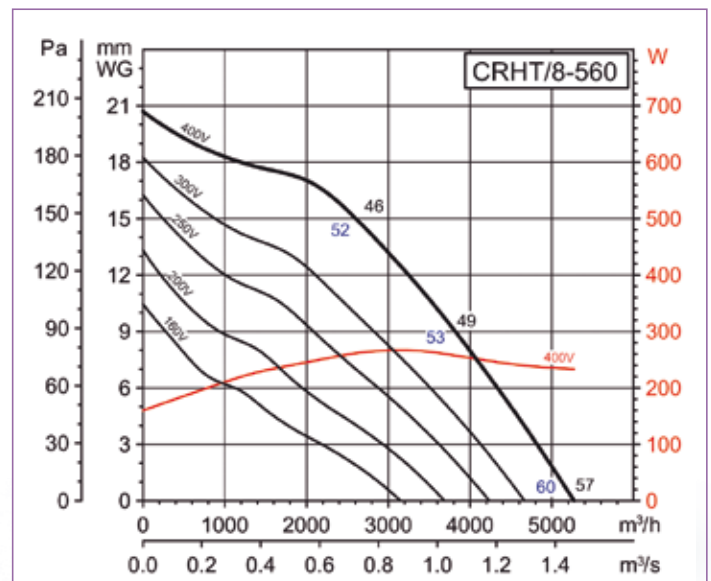
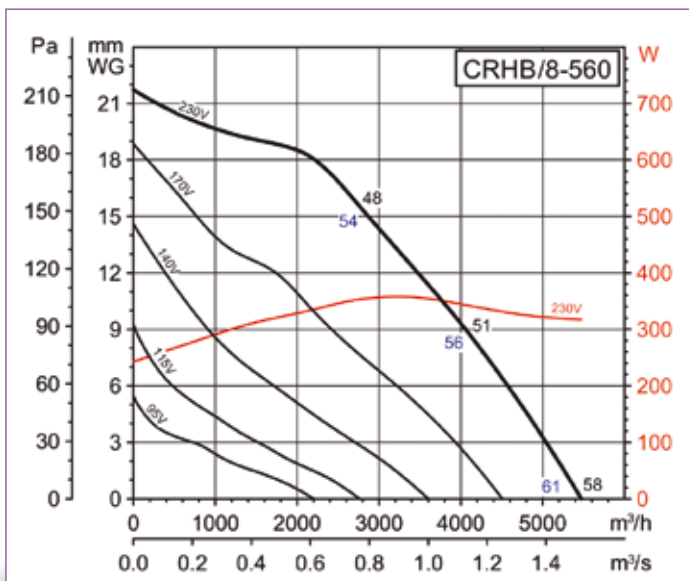
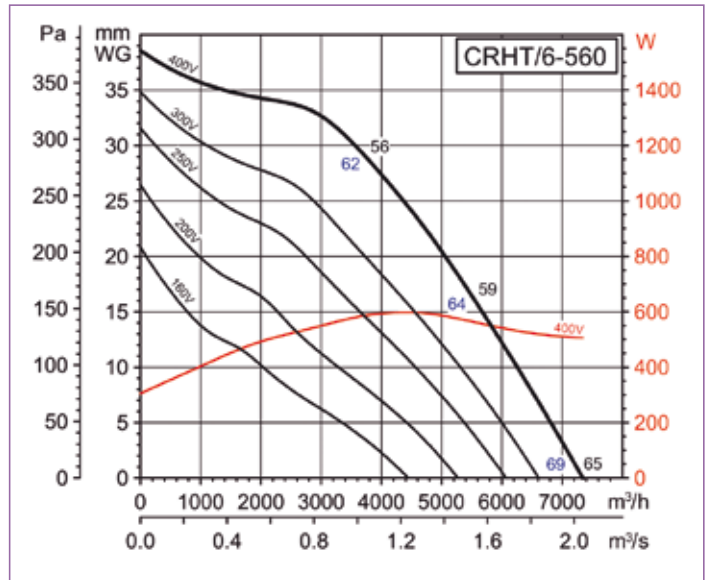
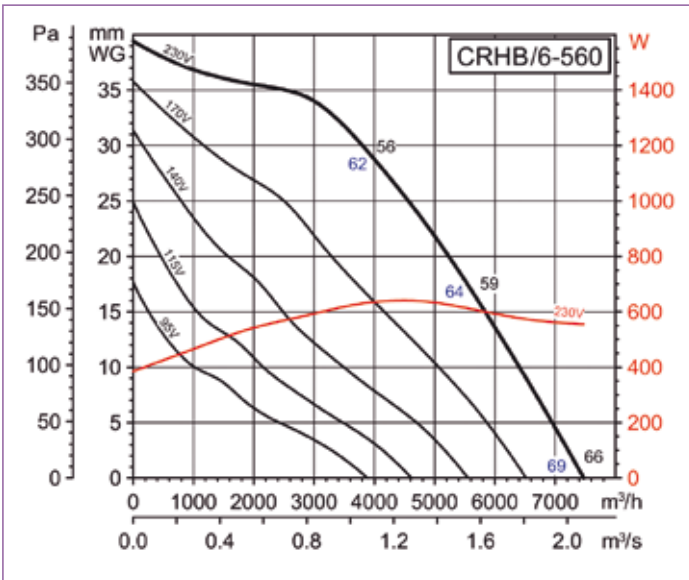
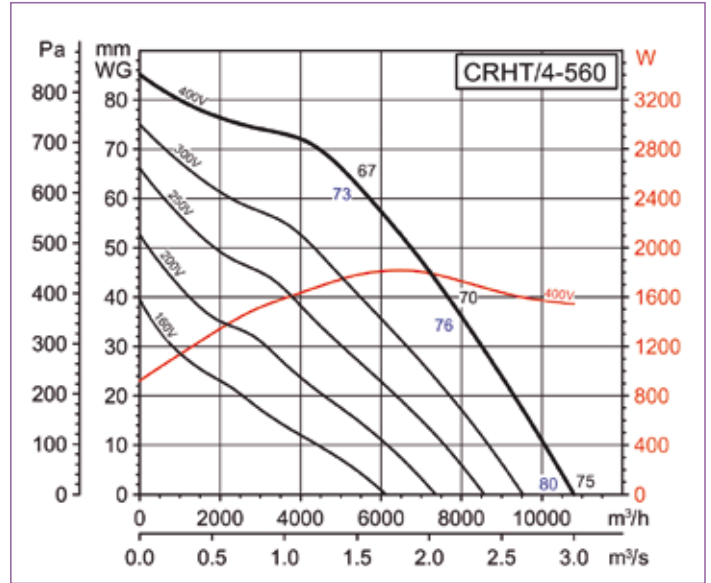

Performance curves CRHB/CRHT

The values are sound pressure levels measured at 1,5 m, in free field conditions, at the fan inlet (black) and outlet (blue).

CRHB/CRHT

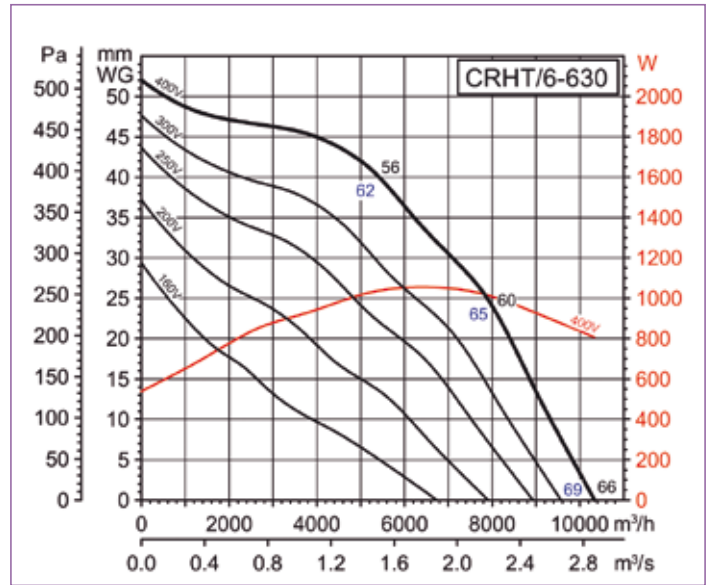
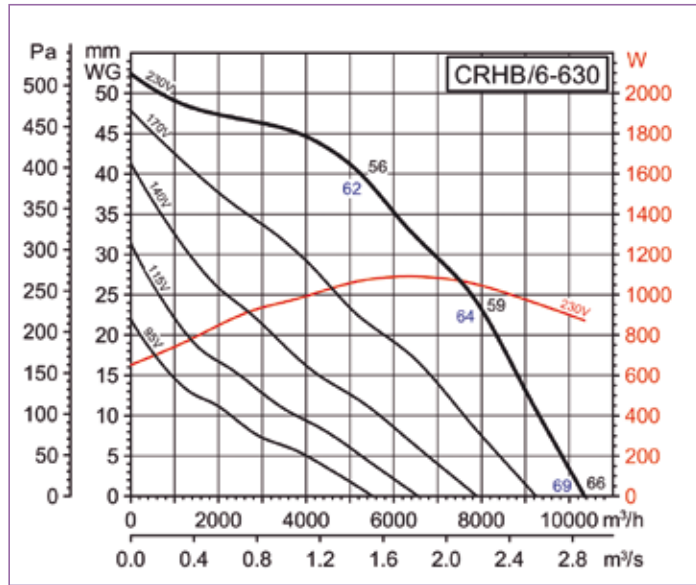

Roof mounted fans

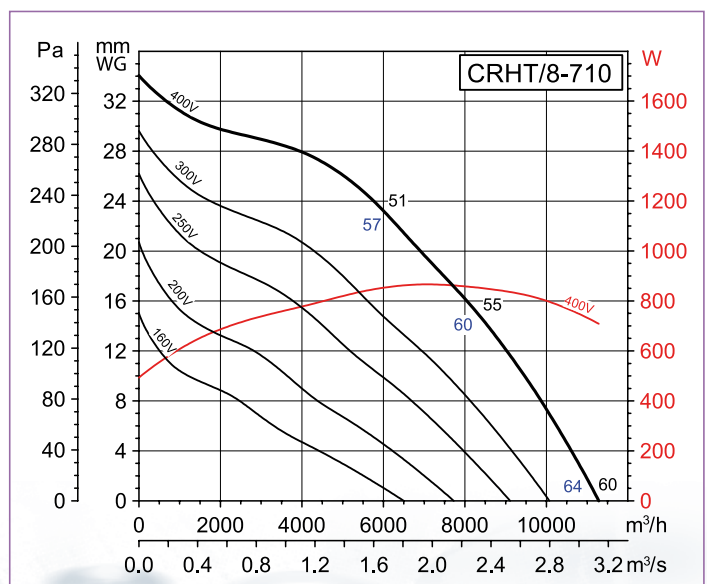
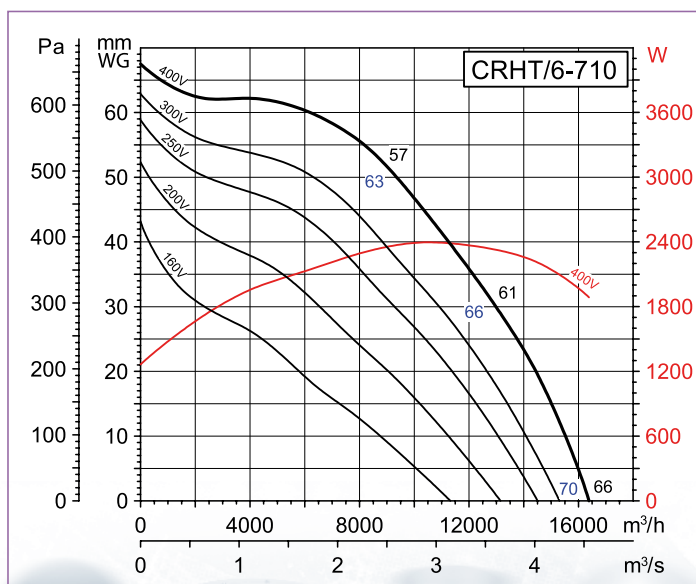
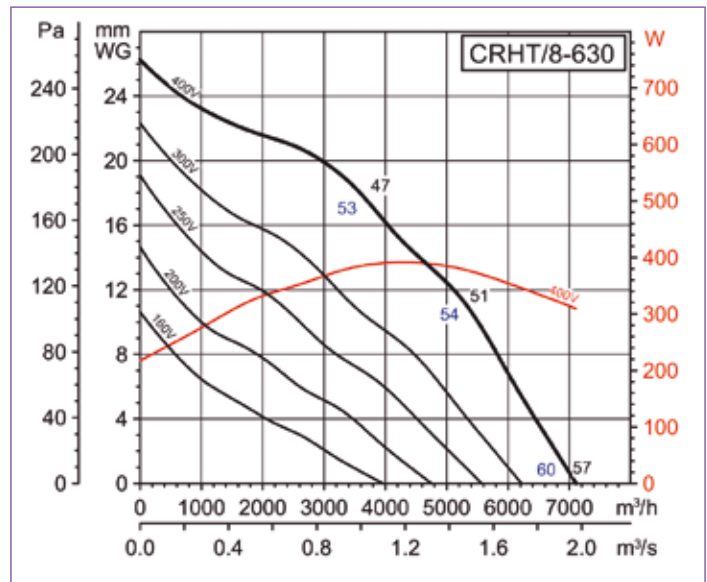
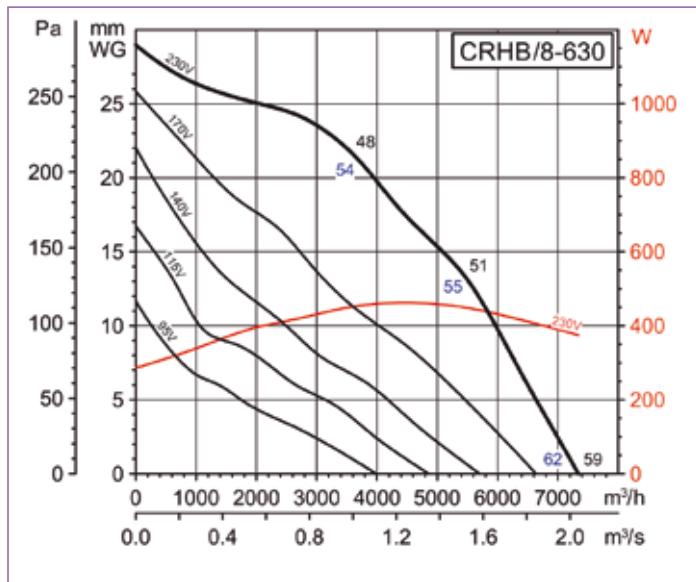

■ Performance curves CRVB/CRVT

The values are sound pressure levels measured at 1,5 m, in free field conditions, at the fan inlet (black) and outlet (blue).

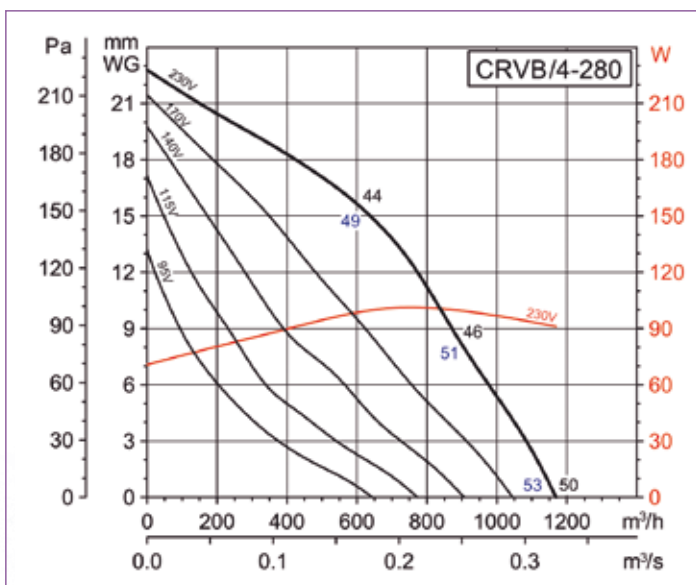
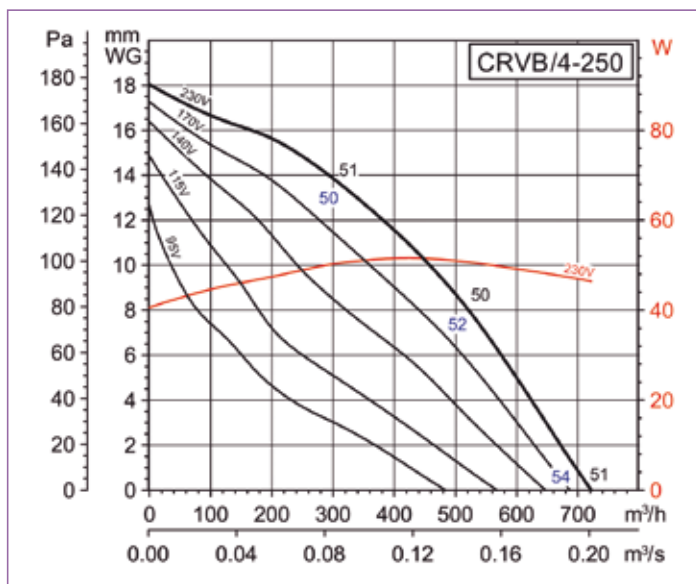
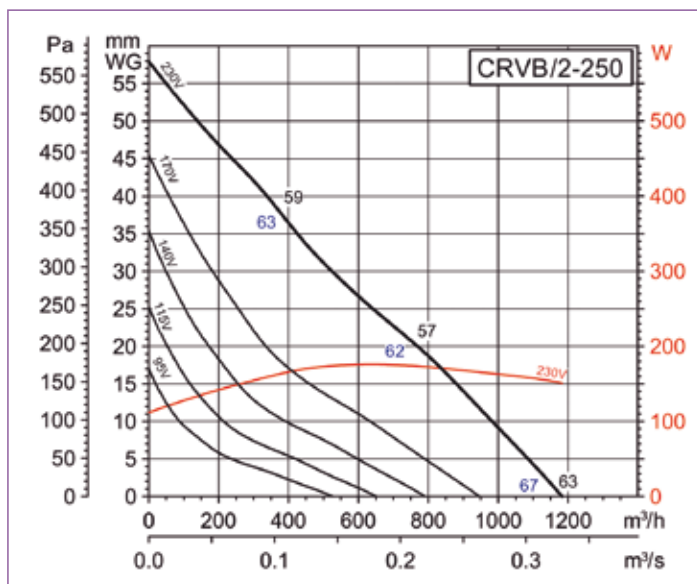
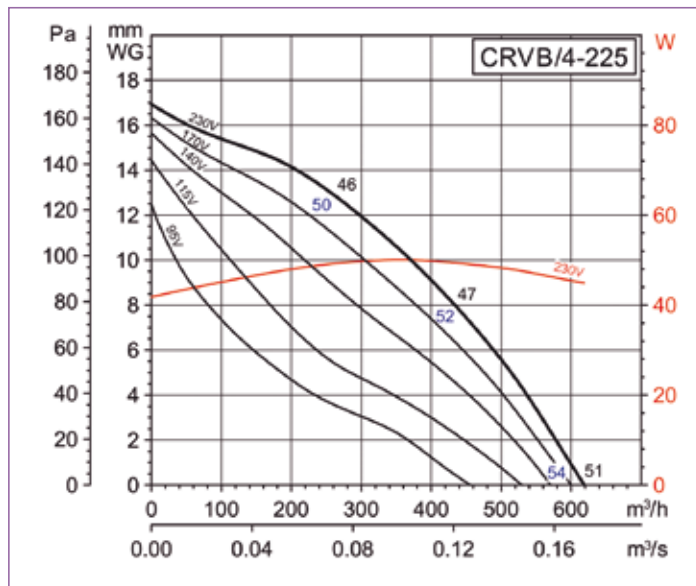
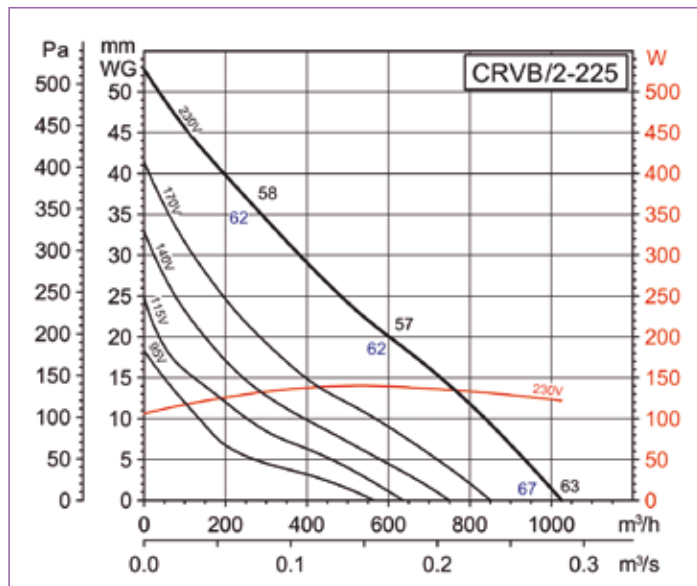

■ Performance curves CRVB/CRVT

The values are sound pressure levels measured at 1,5 m, in free field conditions, at the fan inlet (black) and outlet (blue).

CRVB/CRVT

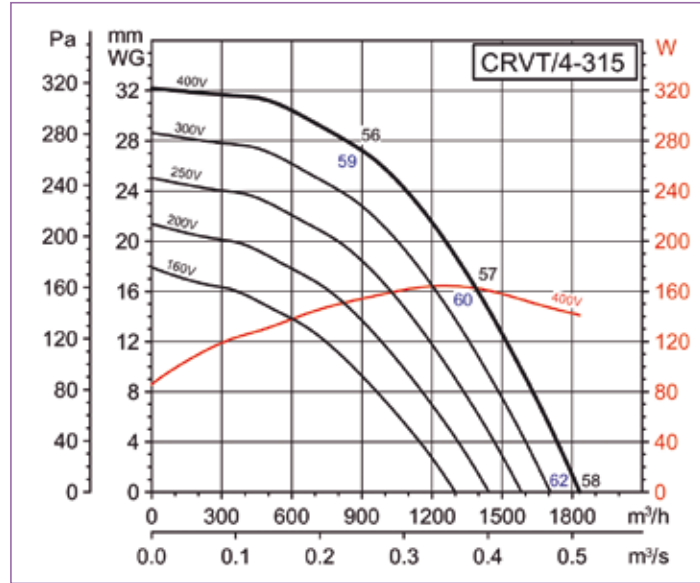
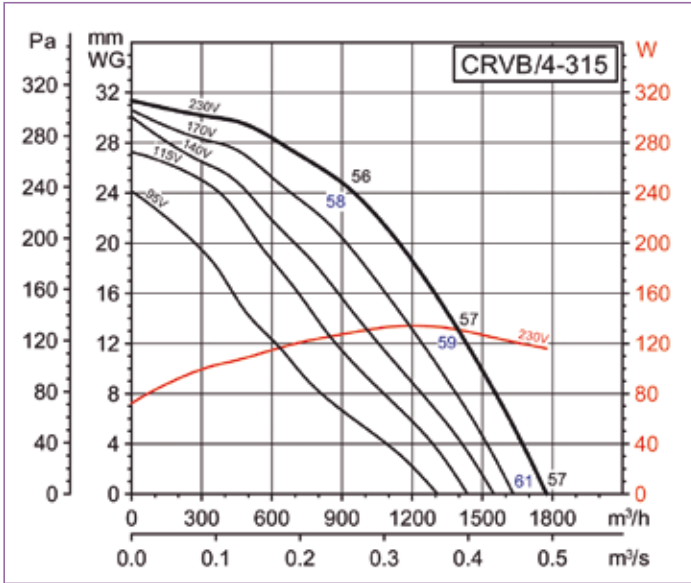

Roof mounted fans

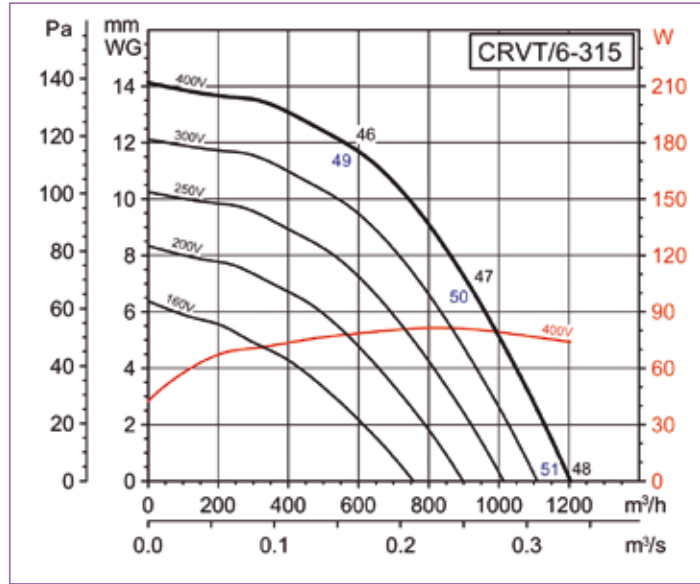
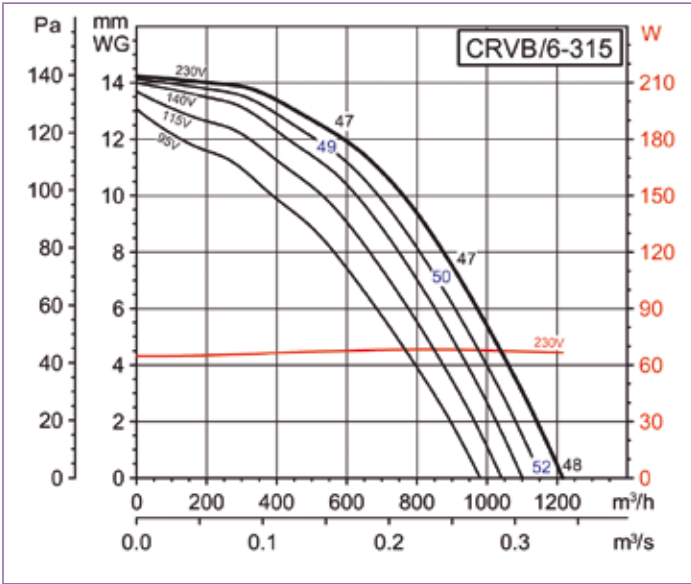

■ Performance curves CRVB/CRVT

The values are sound pressure levels measured at 1,5 m, in free field conditions, at the fan inlet (black) and outlet (blue).

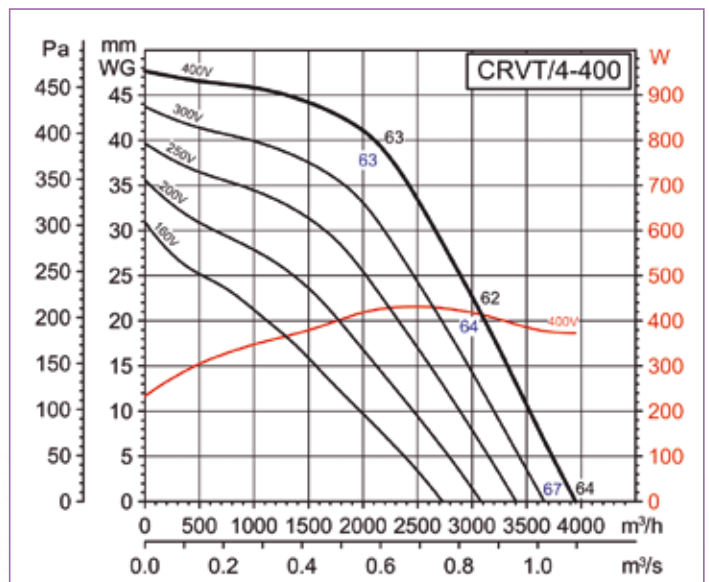
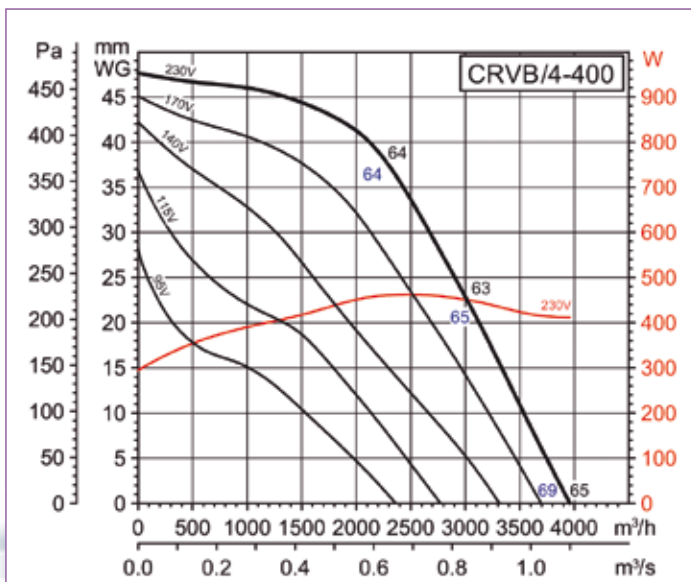
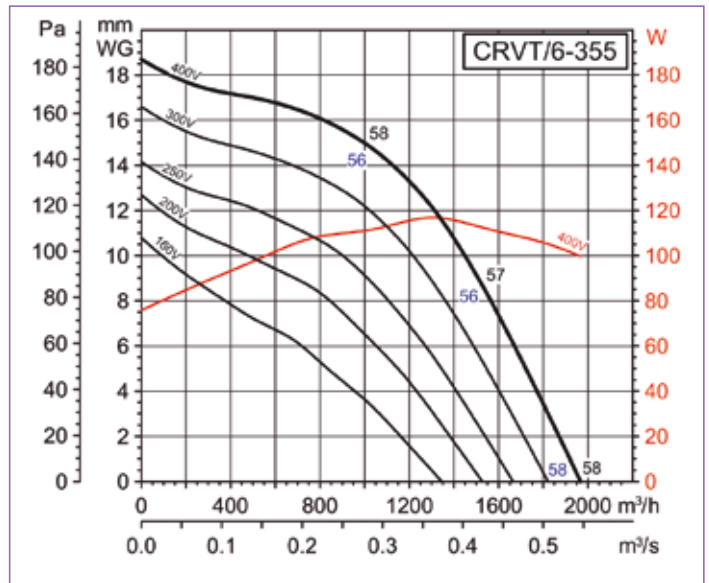
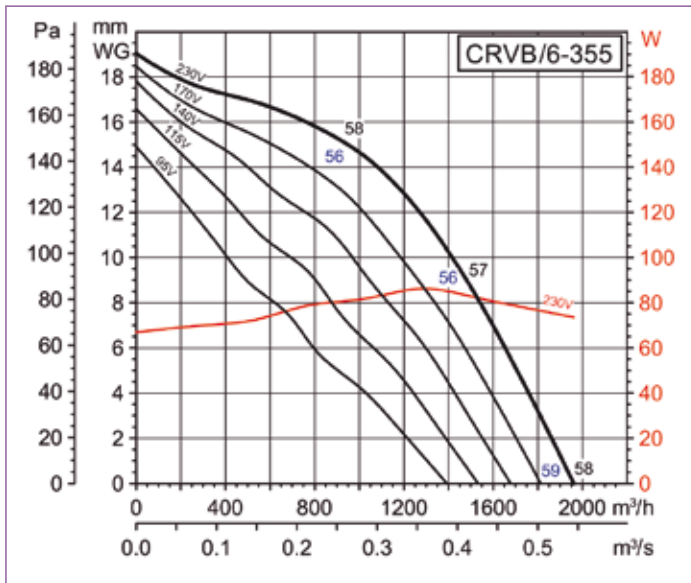
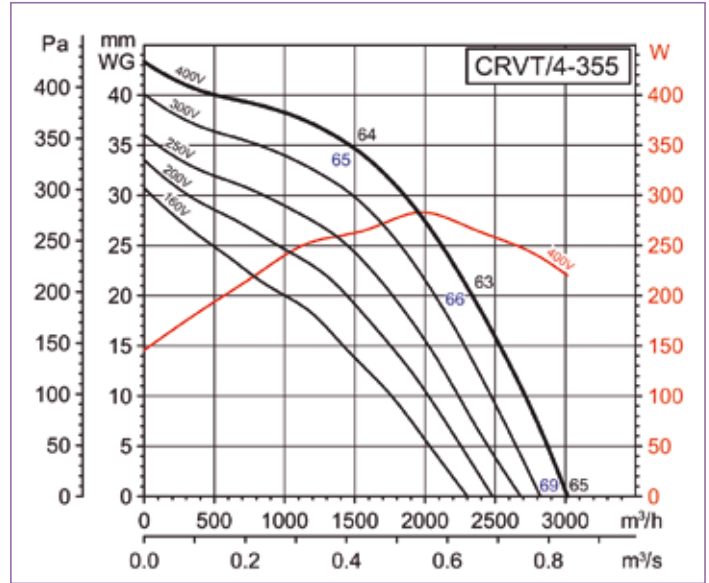
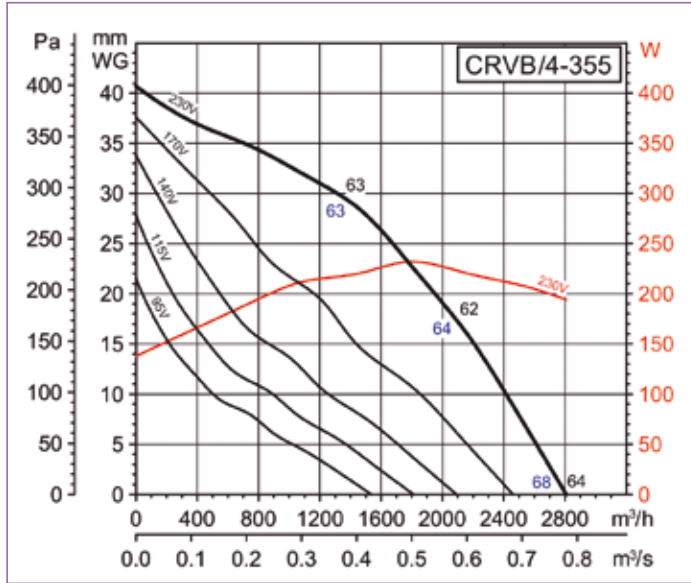

Performance curves CRVB/CRVT

The values are sound pressure levels measured at 1,5 m, in free field conditions, at the fan inlet (black) and outlet (blue).

CRVB/CRVT

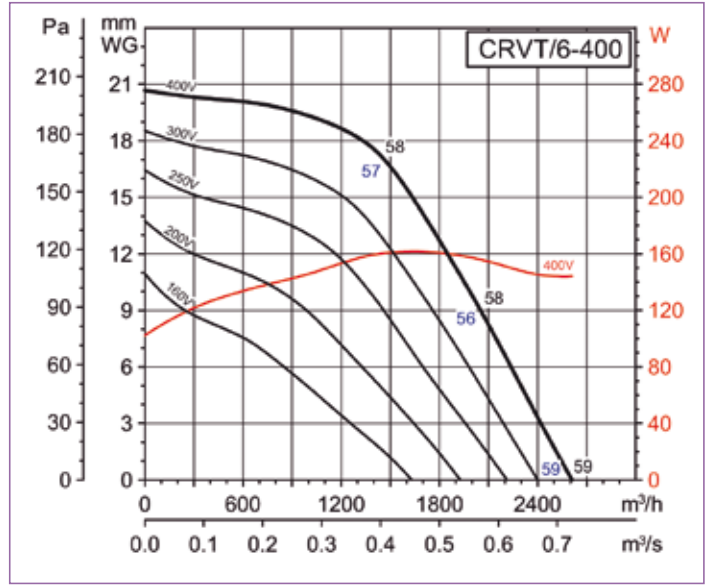
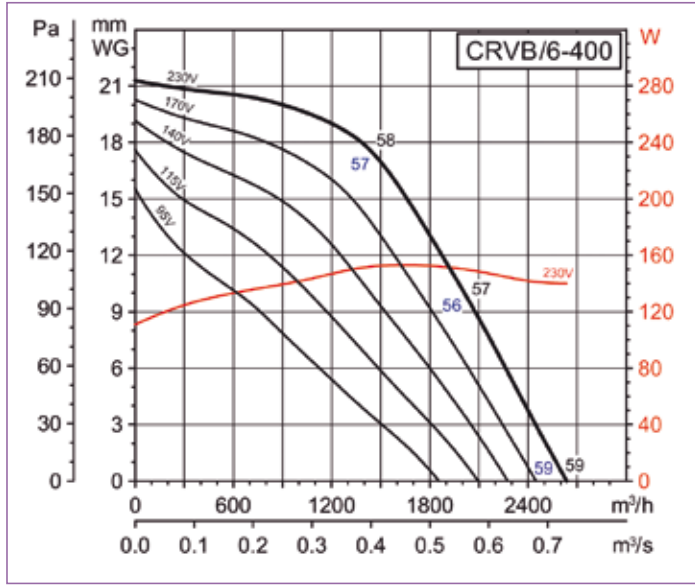

Roof mounted fans

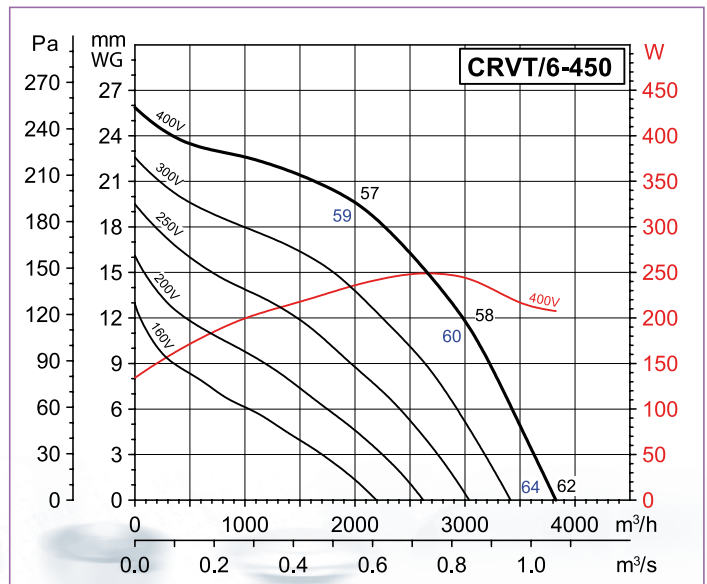
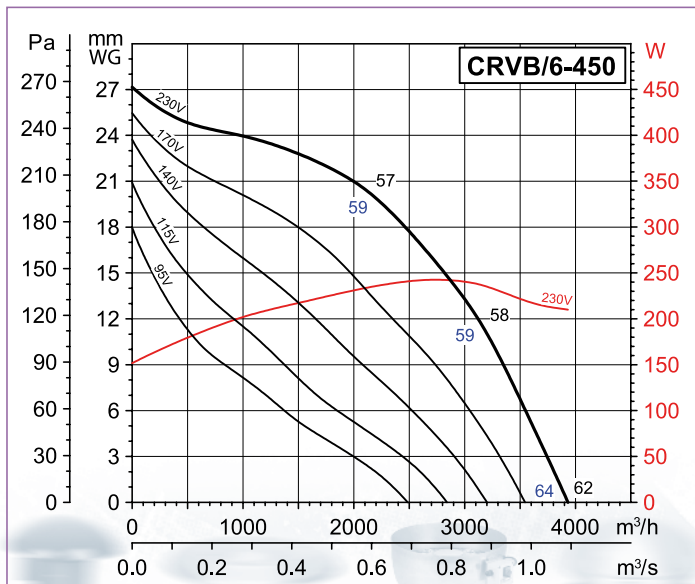
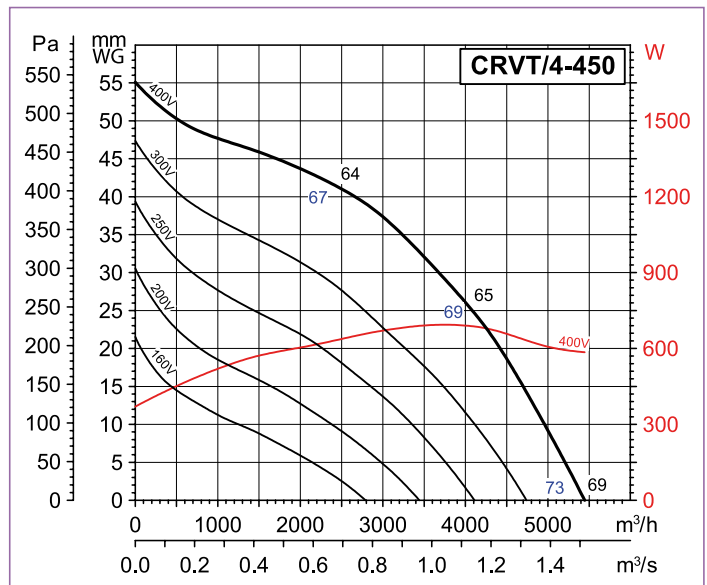
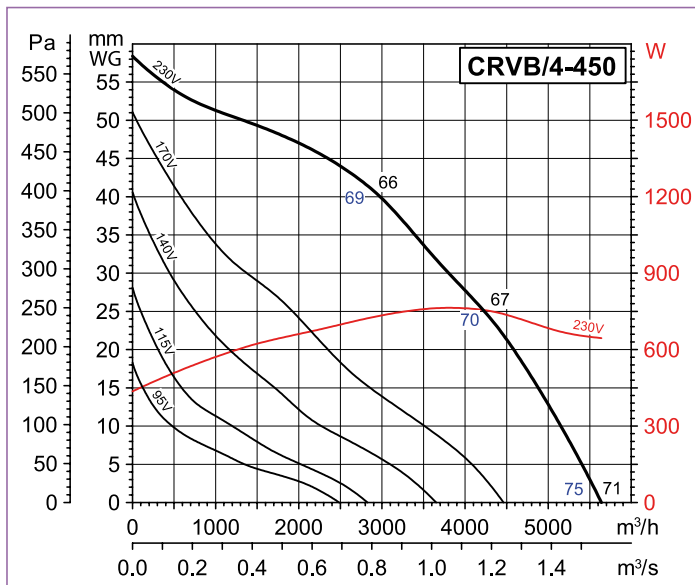

■ Performance curves CRVB/CRVT

The values are sound pressure levels measured at 1,5 m, in free field conditions, at the fan inlet (black) and outlet (blue).

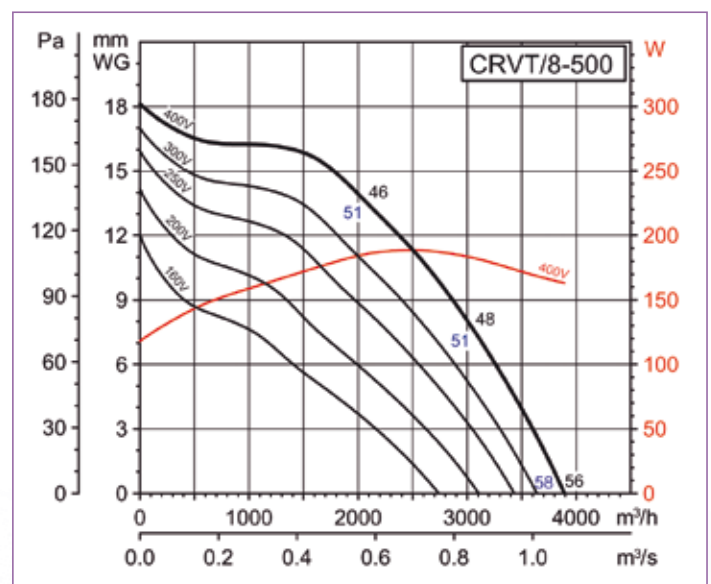
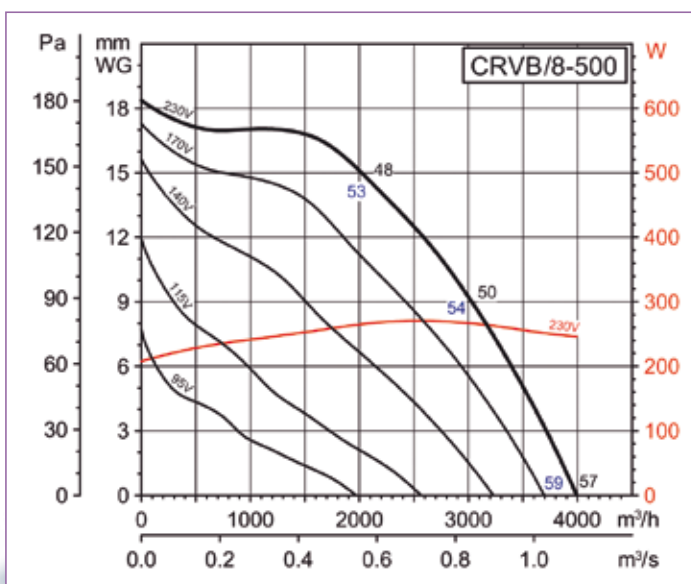
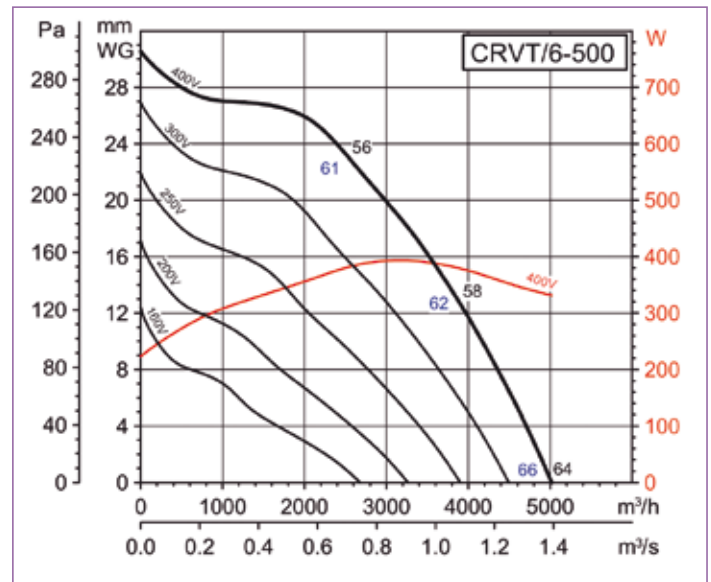
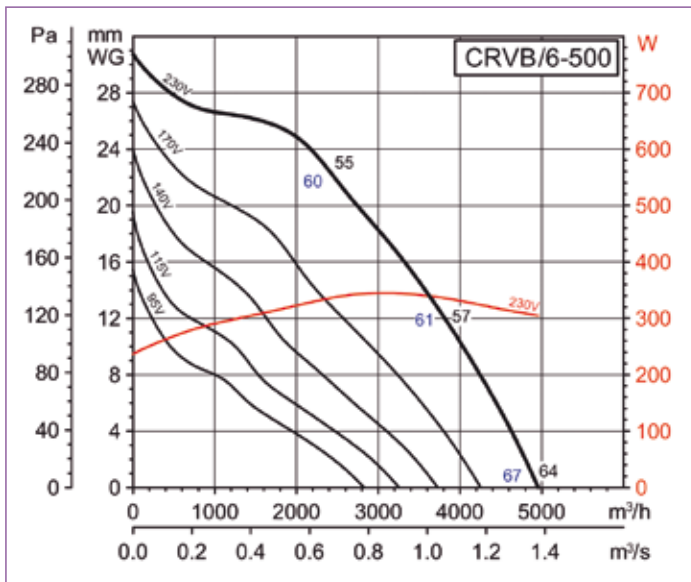
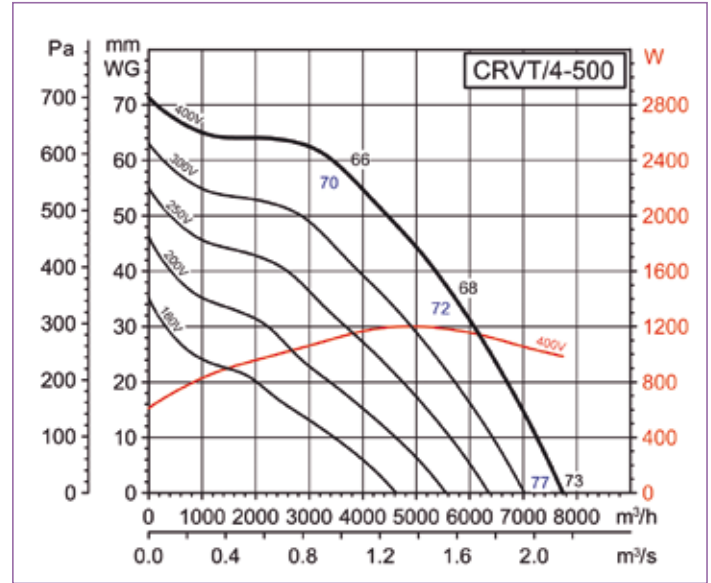
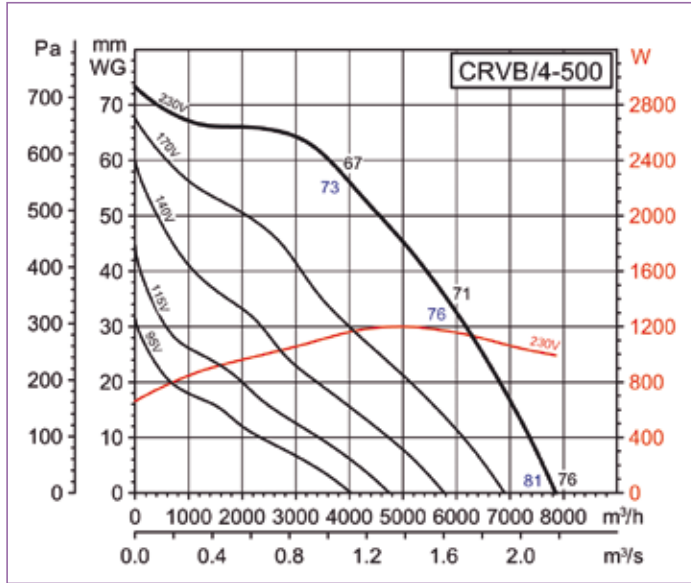

Performance curves CRVB/CRVT

The values are sound pressure levels measured at 1,5 m, in free field conditions, at the fan inlet (black) and outlet (blue).

CRHB/CRHT

Roof mounted fans

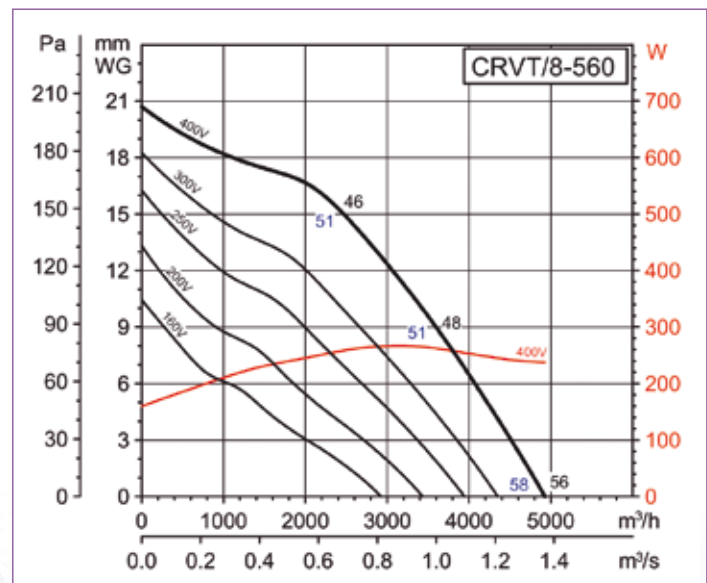
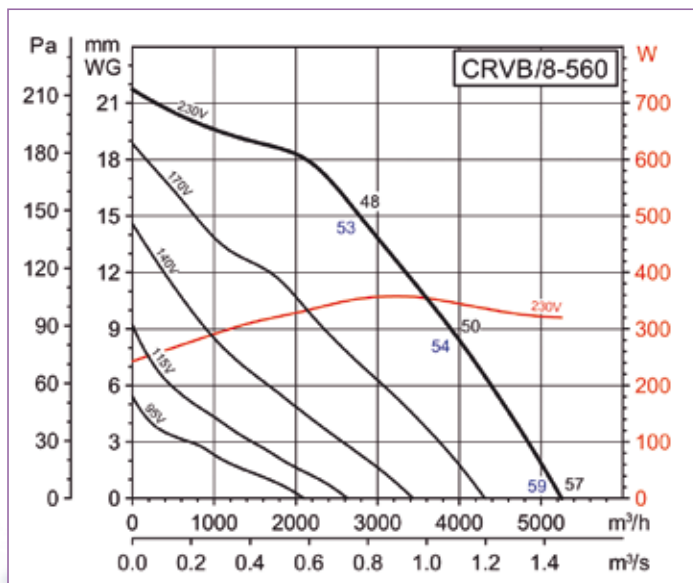
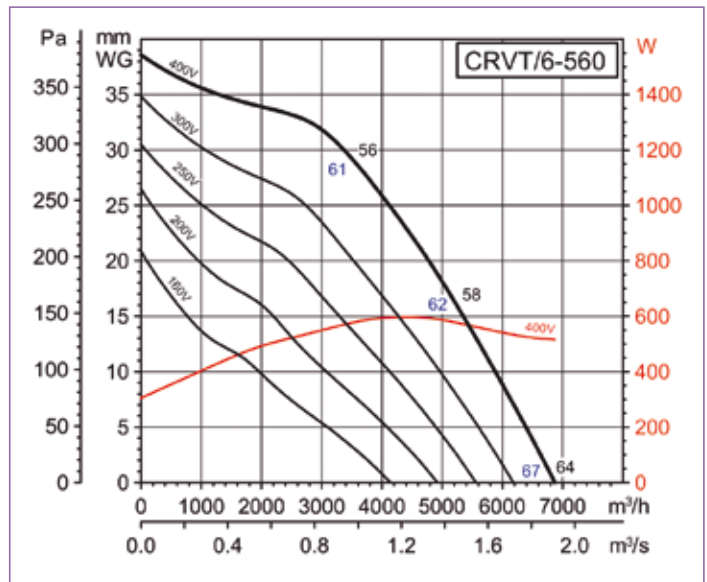
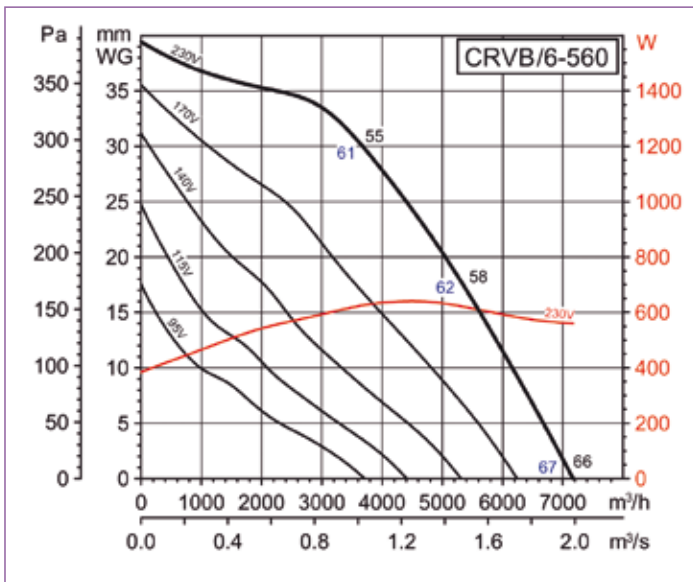
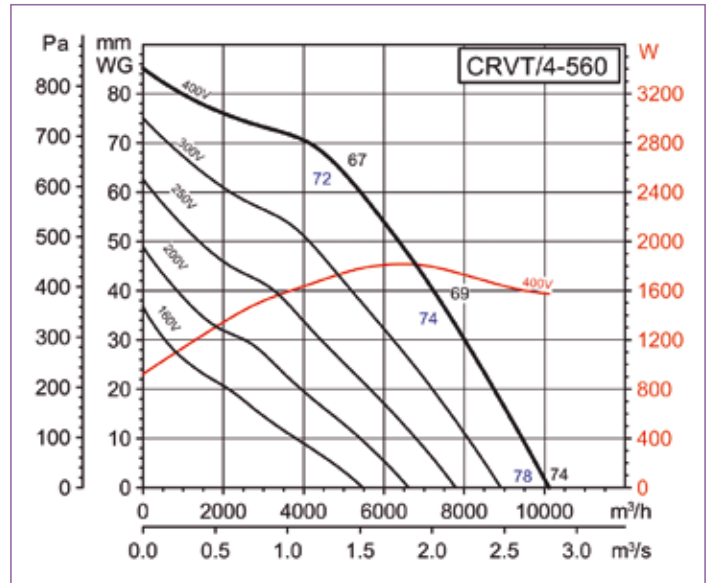

■ Performance curves CRVB/CRVT

The values are sound pressure levels measured at 1,5 m, in free field conditions, at the fan inlet (black) and outlet (blue).

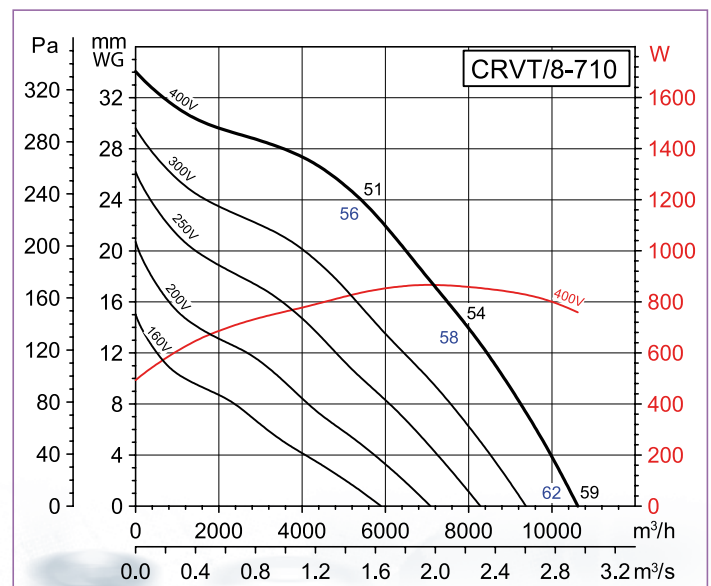
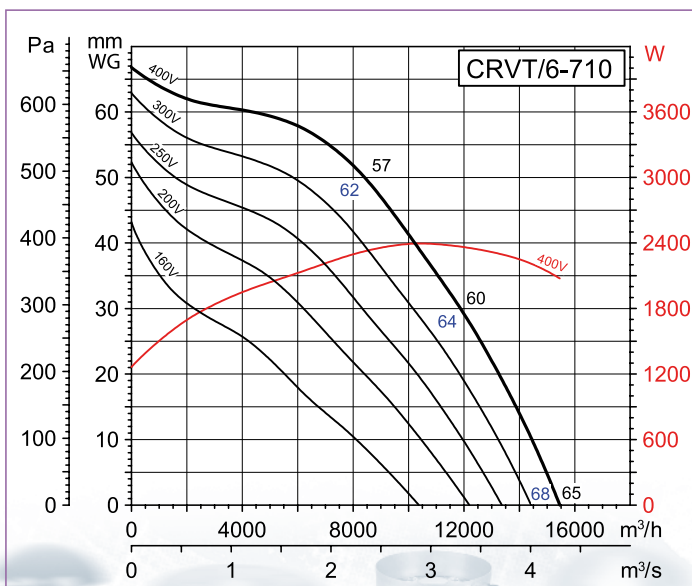
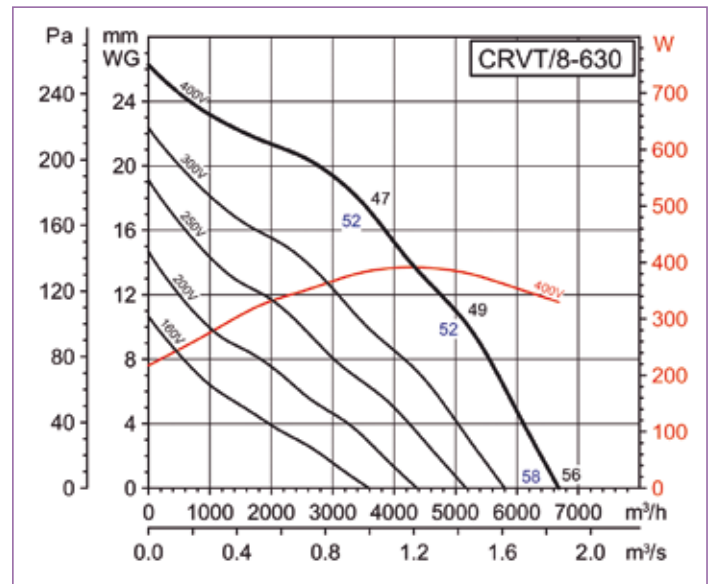
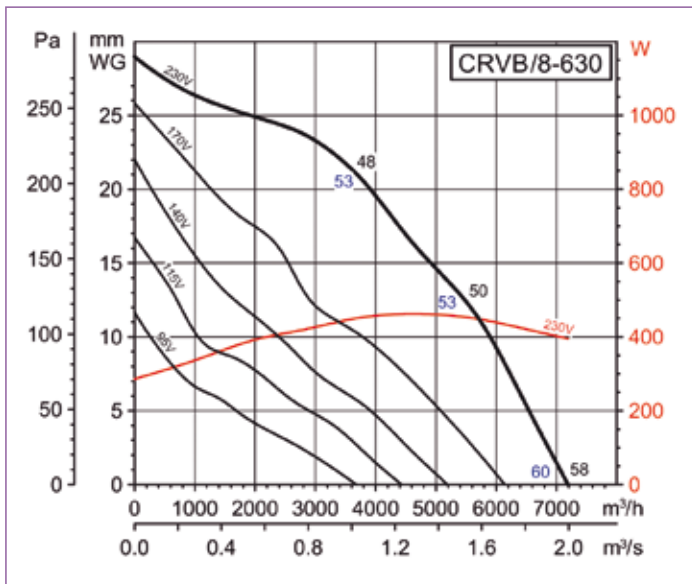
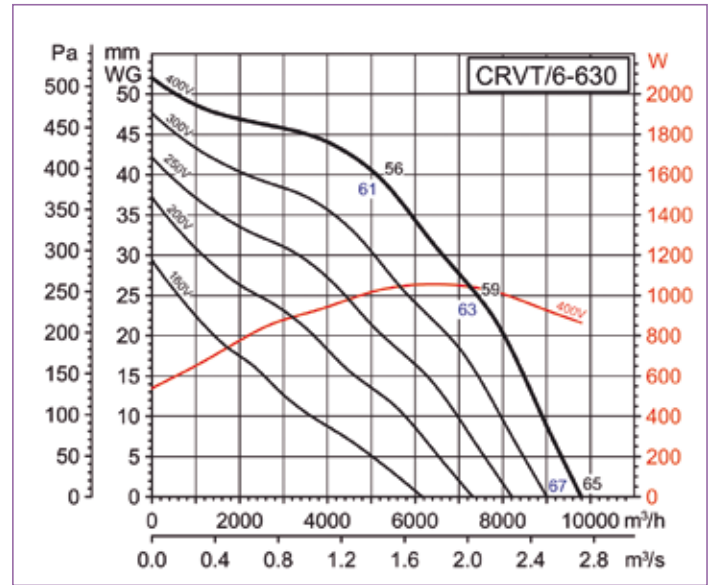
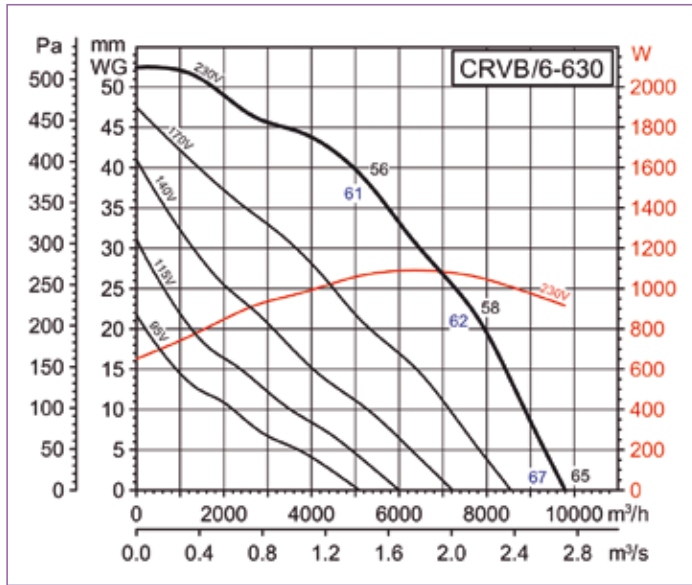

■ Dimensions CRHB/CRHT

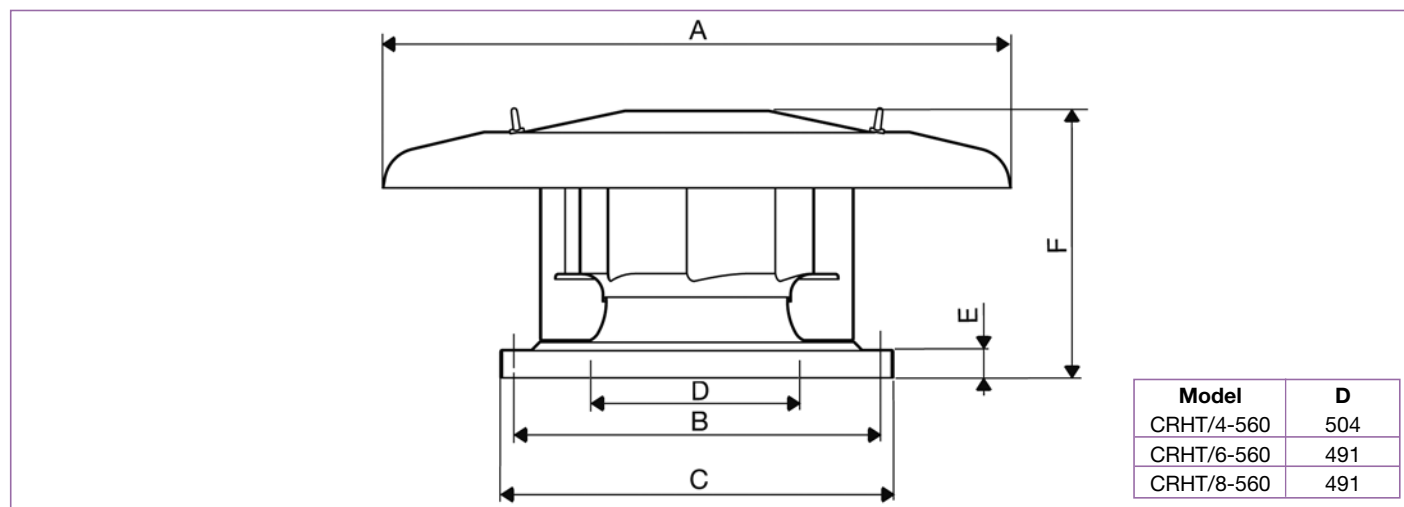

Model	ØA	B	C	D	E	F	Model	ØA	B	C	D	E	F
225	570	245	326	180	35	223	450	1150	535	630	400	40	418
250	570	245	326	180	35	223	500	1150	535	630	400	40	474
280	570	330	435	250	40	250	560	1150	590	710	500	40	See image
315	760	330	435	250	40	333	630	1150	750	905	630	50	546
355	895	450	560	355	40	356,5	710	1300	750	905	630	50	604
400	895	450	560	355	40	382							

■ Installation CRHB/CRHT

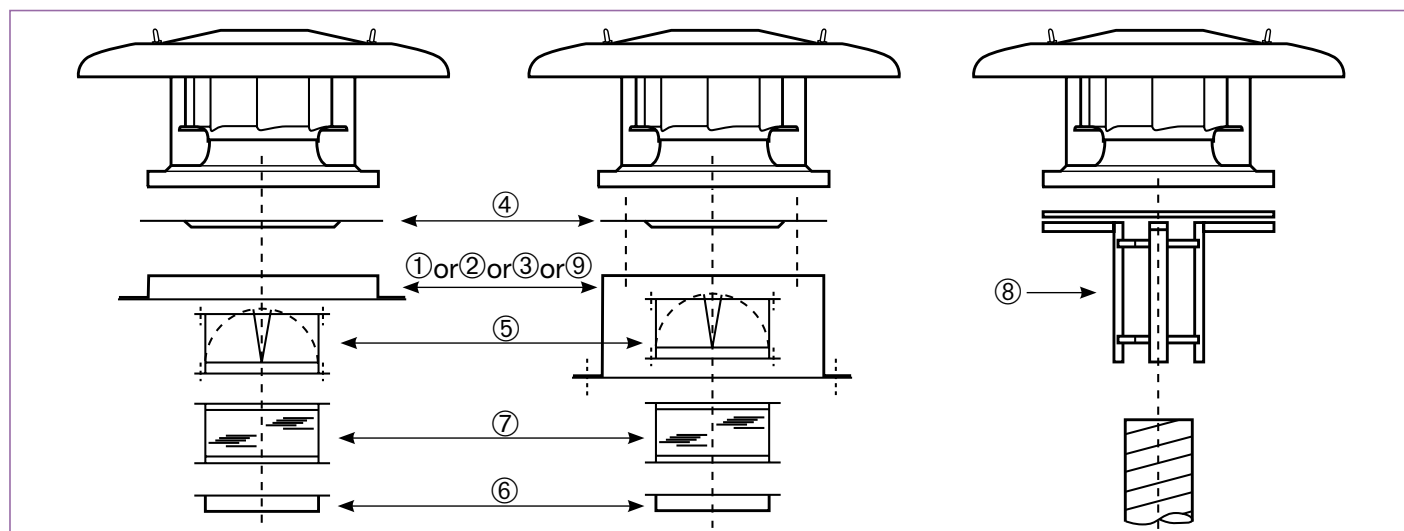

Model of fan	① Sealing frame	② Flat roof insulated up stand	③ Acoustic up stand	④ Accessory adapter plate	⑤ Back draft shutter	⑥ Flange with spigot	⑦ Flexible coupling	⑧ Circular adapter	⑨ Support base for inclined curb mounted installations
225 250	JMS-300	JBS-300	JAA-300	JPA-300	JCA-300	JBR-300	JAЕ-300	JCC-300	BI-3
280 315	JMS-435	JBS-435	JAA-435	JPA-435	JCA-435	JBR-435	JAЕ-435	JCC-435	BI-4
355 400	JMS-560	JBS-560	JAA-560	JPA-560	JCA-560	JBR-560	JAЕ-560	JCC-560	BI-5
450 500	JMS-630	JBS-630	JAA-630	JPA-630	JCA-630	JBR-630	JAЕ-630	JCC-630	BI-6
560	JMS-710	JBS-710	JAA-710	JPA-710	JCA-710	JBR-710	JAЕ-710	-	BI-7
630 710	JMS-905	JBS-905	JAA-905	JPA-905	JCA-905	JBR-905	JAЕ-905	JCC-905	BI-9

■ Dimensions CRVB/CRVT

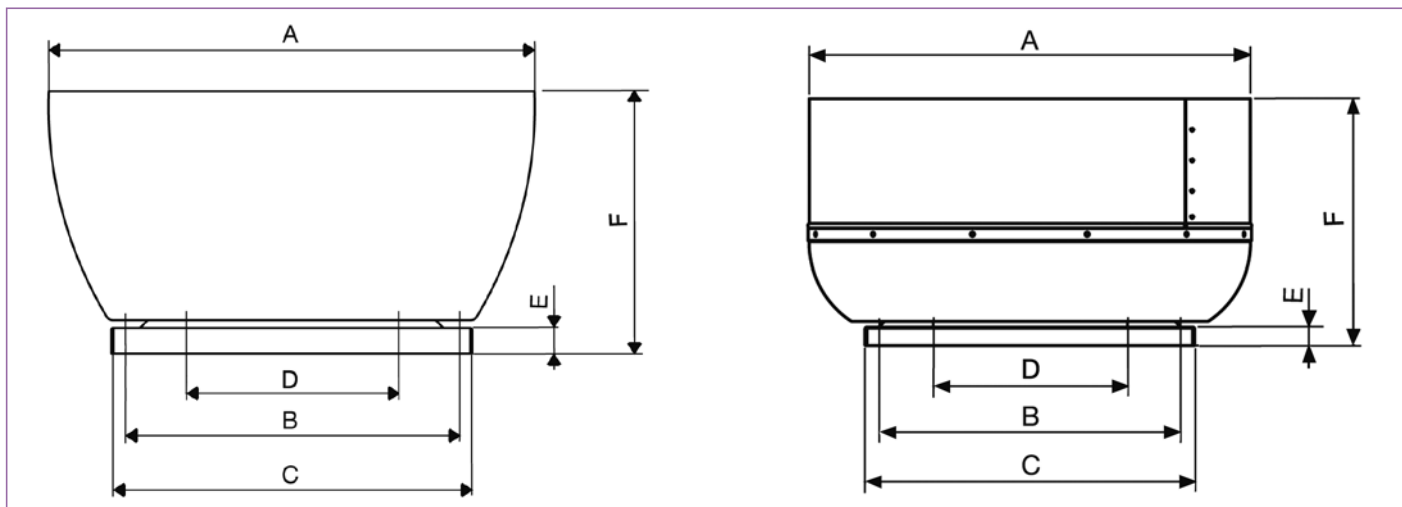

Model	ØA	B	C	D	E	F
225	434	245	326	180	40	257
250	434	245	326	180	40	257
280	560	330	435	250	40	317
315	560	330	435	250	40	347
355	754	450	560	355	40	407
400	754	450	560	335	40	407
450	857	535	630	335	40	471

Model	ØA	B	C	D	E	F
500	857	535	630	400	40	471
560	950	590	710	400	40	481
630	1216	750	905	500	50	634
710	1216	750	905	630	50	634

■ Installation CRVB/CRVT

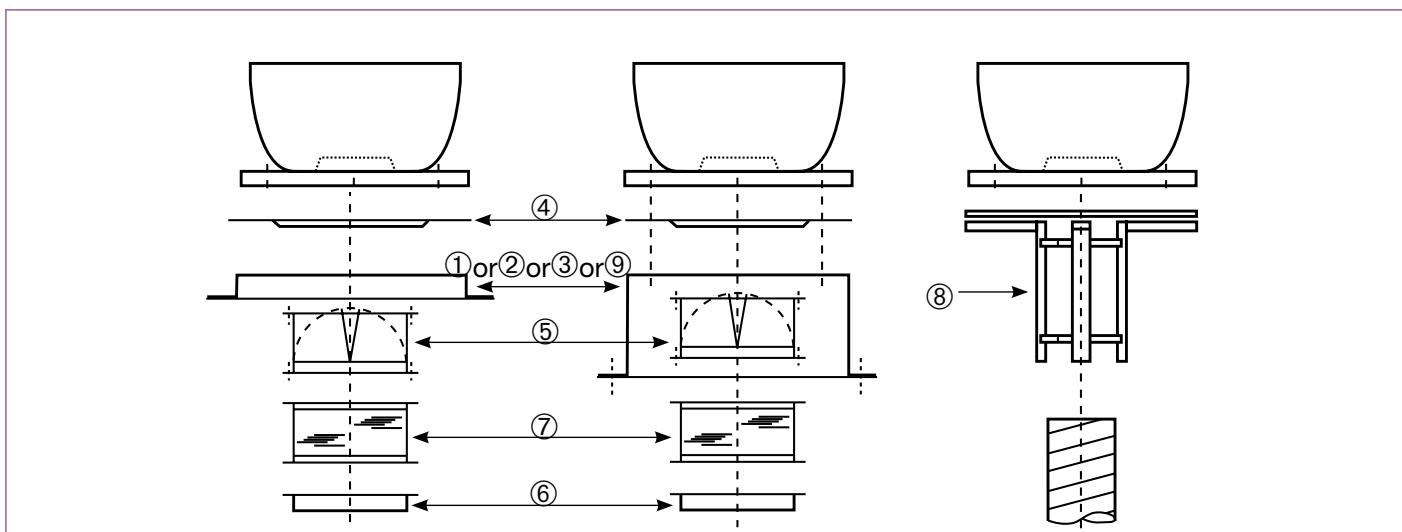

Model of fan	① Sealing frame	② Flat roof insulated up stand	③ Acoustic up stand	④ Accessory adapter plate	⑤ Back draft shutter	⑥ Flange with spigot	⑦ Flexible coupling	⑧ Circular adapter	⑨ Support base for inclined curb mounted installations
225 250	JMS-300	JBS-300	JAA-300	JPA-300	JCA-300	JBR-300	JAE-300	JCC-300	BI-3
280 315	JMS-435	JBS-435	JAA-435	JPA-435	JCA-435	JBR-435	JAE-435	JCC-435	BI-4
355 400	JMS-560	JBS-560	JAA-560	JPA-560	JCA-560	JBR-560	JAE-560	JCC-560	BI-5
450 500	JMS-630	JBS-630	JAA-630	JPA-630	JCA-630	JBR-630	JAE-630	JCC-630	BI-6
560	JMS-710	JBS-710	JAA-710	JPA-710	JCA-710	JBR-710	JAE-710	-	BI-7
630 710	JMS-905	JBS-905	JAA-905	JPA-905	JCA-905	JBR-905	JAE-905	JCC-905	BI-9

■ Mounting accessories

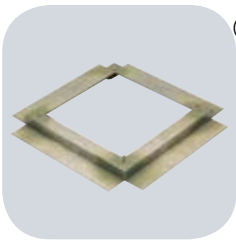

- ① **Sealing Frame JMS**
- For mounting a roof fan on an up stand or base
 - Supplied with screws and gasket for a complete weatherproof seal.

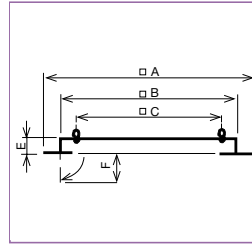

Model JMS	□ A	□ B	□ C	E	F
300	470	290	245	50	70
435	600	420	330	50	70
560	725	545	450	50	70
630	795	615	535	50	70
710	875	695	590	50	70
905	1065	885	750	60	70

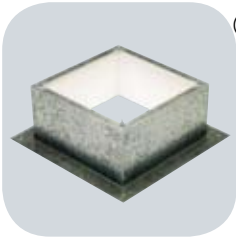

- ② **Flat Roof Up stand JBS**
- For mounting a fan on a flat roof without up stands
 - For use on horizontal roofs
 - Internal insulation to prevent condensation
 - Supplied with screws and gasket for a complete weather seal

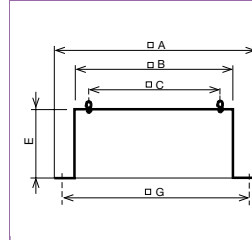

Model JBS	□ A	□ B	□ C	E	□ G
300	470	289	245	300	380
435	600	419	330	300	510
560	725	544	450	300	635
630	795	614	535	300	705
710	875	694	590	300	785
905	1065	884	750	300	975



- ③ **Accessory Adapter Plate JPA**
- Used when mounting the accessories (JCA, JBR, JAE)
 - Allows the fan to be disconnected from the upstand without having to remove the duct

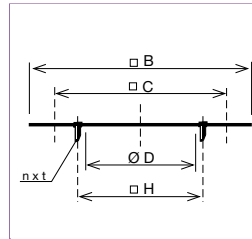

Model JPA	□ B	□ C	∅ D	next	∅ H
300	289	245	182	4xM6	205
435	419	330	252	4xM8	280
560	544	450	358	8xM8	395
630	614	535	403	8xM10	450
710	694	590	503	12xM10	560
905	884	750	633	12xM10	690

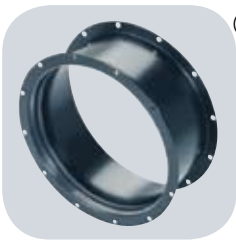

- ④ **Backdraft Shutter JCA**
- Prevents backdraft when the fan is not operating
 - To be mounted at the fan inlet with the JPA plate

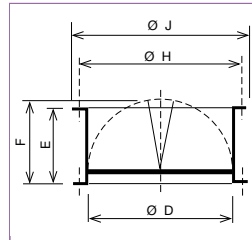

Model JCA	∅ D	E	F	∅ H	∅ J
300	182	100	124	205	219
435	252	145	174	280	300
560-N	358	210	227	395	415
630-N	403	240	250	450	474
710-N	503	285	300	560	581
905-N	633	345	365	690	714



- ⑤ **Flange JBR**
- For use when circular connection is required directly to the fan
 - To be mounted at the fan inlet with the JPA plate or fixed directly to the fan base (rivets or screws not supplied)

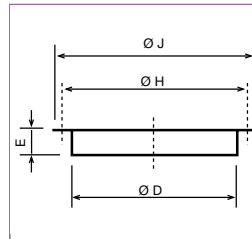

Model JBR	∅ D	E	∅ H	∅ J
300	182	55	205	219
435	252	55	280	300
560	358	55	395	415
630	403	63	450	474
710	503	69	560	581
905	633	69	690	714

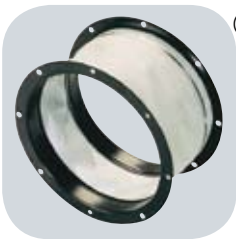

- ⑥ **Flexible Coupling JAE**
- Reduces the transmission of vibrations when the duct is connected directly to the fan
 - To be mounted at the fan inlet with JPA plate

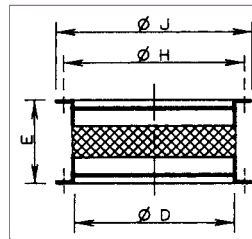

Model JAE	∅ D	E	∅ H	∅ J
300	182	254	205	219
435	252	254	280	300
560	358	254	395	415
630	403	254	450	474
710	503	254	560	581
905	633	254	690	714



- ⑦ **Adapter For Circular Duct JCC**
- For use when fitting the models up to 400, directly to a spirally wound circular duct

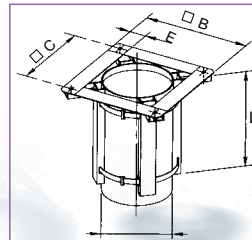

Model JCC	∅ B	∅ C	∅ D	E	L
300	290	245	180	45	350
435	390	330	250	60	350
560	520	450	355	70	350
630	605	535	400	70	350



- ⑨ **BI support base for inclined curb mounted installations**
 – To ensure a proper installation of the CRHB-CRHT roof fan it is essential to specify the roof pitch angle and the distance between the roof beam profiles

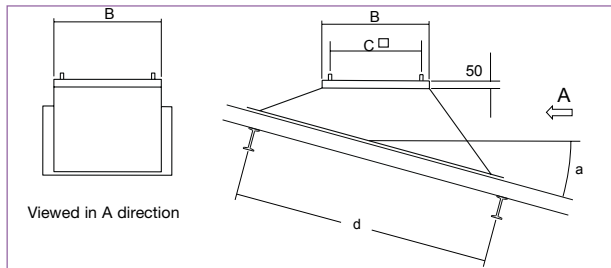

d: Distance between the roof beam profiles a: Roof pitch angle (curb)

	B	C
BI-3	289	245
BI-4	419	330
BI-5	544	450
BI-6	614	535
BI-7	694	590
BI-9	884	750

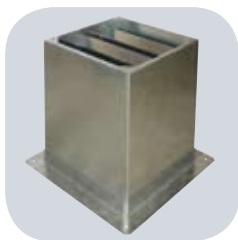

- ③ **Acoustic Up Stand JAA**
 – Reduces in duct and radiated noise
 – For use when mounting a fan on a flat roof without up stands
 – Supplied with screws and gasket for a complete weather seal

Mod. JAA	□ A	□ B	□ C	∅ D (M)	H	□ G
300	470	290	245	13 (M10)	750	380
435	600	419	330	15 (M12)	750	510
560	725	545	450	15 (M12)	750	635
630	795	615	535	15 (M12)	750	705
710	875	695	590	18 (M14)	1000	785
905	1065	885	750	18 (M14)	1000	975

Acoustic attenuation in dB(A) at the corresponding frequency band in Hz

Model	125	250	500	1000	2000	4000	8000
JAA-300	1	5	13	22	23	16	12
JAA-435	1	7	16	23	25	18	13
JAA-560	2	8	16	29	32	26	17
JAA-630	2	8	14	24	27	19	13
JAA-710	2	8	14	24	28	16	11
JAA-905	2	7	14	26	30	19	12
JAA-1100	2	7	16	27	32	20	13

JAA Attenuator pressure drops

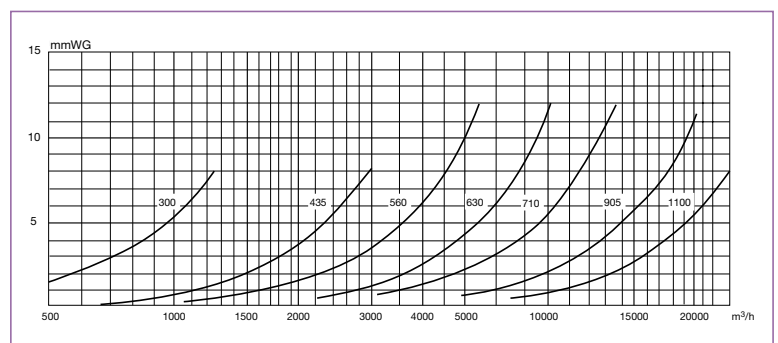

■ Electrical accessories



REB
 Single phase electronic speed controllers.



RMB / RMT
 Auto transformer speed controllers.
 – For single phase and three phase roof fans.



REB-5 / REB-10
 Electronic single-phase speed controller.